

VESSEL®

Screwdrivers & Bits Since 1916



JAPAN
ORIGIN

JIS DRIVE+

VESSEL Co., Inc.
Osaka Japan
www.vessel.co.jp/english/

VESSEL TOOLS U.S.A., INC.
vesseltoolsusa.com/



VESSEL ism



Do not follow the crowd



Constantly adapt to changes



Make no compromise on quality



Value created with customers

CERTIFICATIONS



HISTORY 1916-2023



1916 VESSEL® trademark is registered. The company's name represents its aim to deliver international markets



1933 First Hand Screwdriver catalogue

1952 Authorized to display JIS (Japanese Industrial Standards) mark on Screwdrivers

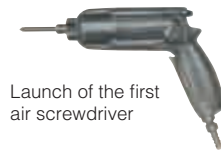

1958 Launch of the first air screwdriver



1962 Foundation of VESSEL® Co. Inc.



1974 Launch of CRYSTALLINE screwdrivers



1981 Win at the Macau Grand Prix



1987 Announcement of the client management system «Q-System»



1999 Launch of the gasoline engine impact wrench



2005 Opening of the french subsidiary and European VESSEL® headquarter



2014 Electric screwdrivers and «power scaler» which drastically improves iron work and shipbuilding



2019 Launch of the USB screwdriver series

1916 1933 1948 1952 1954 1958 1961 1962 1972 1974 1981 1984 1987 1997 1999 2000 2005 2007 2014 2016 2019 2023

1916 Ginosuke Taguchi establishes the Hand Screwdriver manufacturing company in Osaka, Japan



1948 Creation of Nihon Nejimawashi Co.Ltd (transl.: Japan screwdriver)

1954 Begin of manufacturing industrial tools

1961 Invention of the double ended bits



1972 Sunline and Tigerline sets



1974 Launch of Air Nippers



1984 First Ball Grip screwdrivers



1997 The flagship screwdrivers MEGADORA are launched



2000 Anti-static solution product



2007 STAT CLEAN Conductive rubber mat

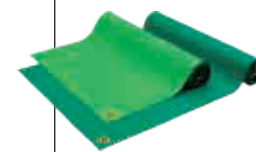

2016 100 Years VESSEL®

100th
VESSEL 1916-2016

Starting of VESSEL TOOLS U.S.A., Inc. in California in 2016



VESSEL HAND TOOLS / SCREWDRIVERS

VESSEL® SHANK TYPES



Bolt shank, diameter of 8 mm or less
With hexagonal bolster for spanner

Standard shank
Popular shank diameter and length based on various standards

Thin shank, diameter of 4 mm
Long slender shank to avoid interference even in a narrow area

Long shank
Suitable for screw tightening in deep area

Stubby shank
Short shank suitable for work in a confined area

JIS DRIVE+



General type
Type in which a shank is held in the handle.

Tang-Thru type
A shank is installed through the handle so that the screwdriver can be used for position adjustment or screw-hole correction by tapping the head with a hammer.

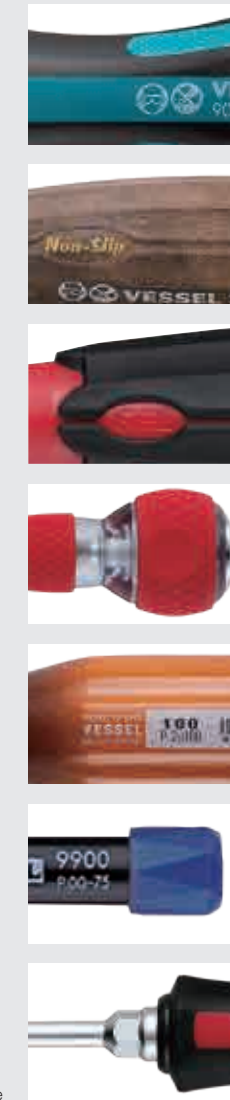

Ergonomic design
The use of design taking into account the shape of the palm ensures comfortable screw tightening.

Non-slip
VESSEL®-developed non-slip surface for the WOOD COMPO range enables torque transmission and screwing even with oily hands.

Cushion handle
Elastic elastomer grip, offering large tightening force.

Ball Grip
Transmits ample tightening force to screw with a comfortable grip fitting to the palm.

Wood handle
Made of natural wood in the tradition of more than a hundred years.

Precision
Designed to transmit a minute force efficiently. Intended for precision work.

Hexagon bolster
This part allows a spanner, etc. to be applied to retighten a screw or undo a hard-tightened screw.



Magnetic

Magnetized tip end
Allows to capture screws for better work efficiency.



Precision and durability
Thanks to high quality materials: Cr (chromium), V (vanadium), Mo (molybdenum)

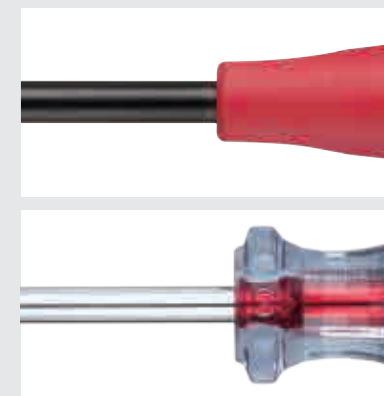

Taper shape
Enabling a screwdriver to be easily taken out of a holder.

Rolling prevention
Avoiding rolling-over, for more security at work

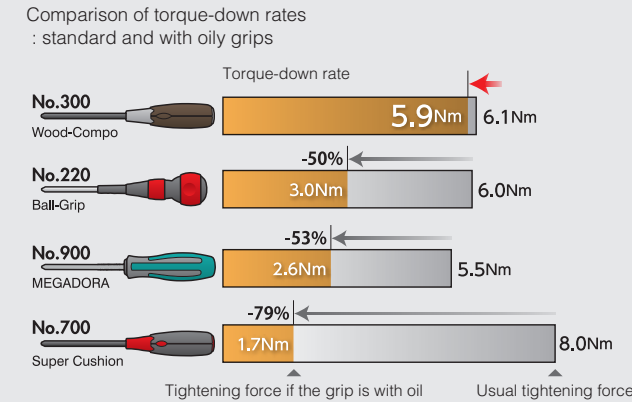

BENEFITS of "MEGADORA"

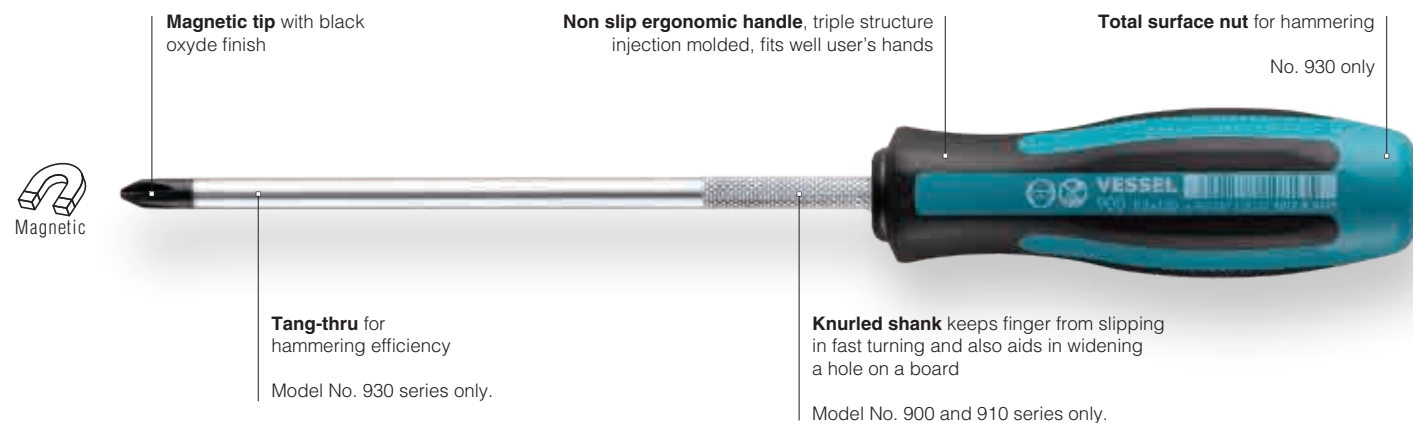

Magnetic tip with black oxide finish

Non slip ergonomic handle, triple structure injection molded, fits well user's hands

Total surface nut for hammering
No. 930 only

Tang-thru for hammering efficiency
Model No. 930 series only.

Knurled shank keeps finger from slipping in fast turning and also aids in widening a hole on a board
Model No. 900 and 910 series only.

JAWSFIT®

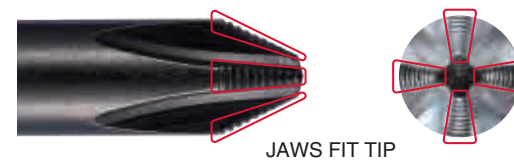

JAWSFIT® technology for better compatibility with the screws. Small projections on the blades, enabling the screwdriver to bite finny into a cross-section of the screw and avoiding cam-out.



IMPACTA
For removing stuck, rusted and distorted screws. Our Tang-thru nut incorporates a cam rotation mechanism which turns the driving tip counter-clockwise by 12° when the handle is hit with a hammer. The IMPACTA system leverages impact acceleration to remove stuck screws.

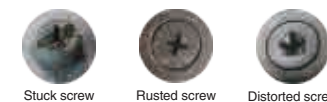

What's new, BALL GRIP™ USB Series

Electric X Manual

Electric-powered quick tightening!! Manual final tightening!!

Product Video



Make your work more efficiently. Easy to use.



USB charging

Charging port

Easy charging with USB port

Micro USB type B



High-brightness LED

LED light

High-brightness LED light that can be used even in dark places.



Off-delay function that glows for 5 seconds after use.

VESSEL can offer wide ranges of bits and bit sets for 220USB.



See page 23 for more details.

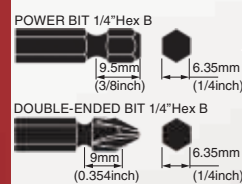

Replacement of the screwdriver bit.

BALL GRIP™ Rechargeable Screwdriver with 25 PC. Bit Set

- Electric output 17.7lbf-in(2.0N·m), No-load speed 280rpm, Manual torque up to 88.5lbf-in(10.N·m)
- With 24pc of bits and 1pc of bit holder.
- Electric power for quick tightening and Manual for final tightening.
- With High Brightness LED light.
- Built in USB Recharge Li-ion Battery (3.6V-800mAh).
- 6.35mm HEX shank.



Package

Contents

- 220USB-1U(Higher Torque model) x 1pc
- Impact Ball Torsion Bit (30mm) x 24pc
- Impact Ball Bit holder x 1pc
- USB Charging Cable (Micro USB Type B) (1m) x 1pc

Electric Output 17.7 lbf-in	No-load Speed 280 rpm	Manual Torque Up to 88.5 lbf-in
---------------------------------------	---------------------------------	-------------------------------------------

Model No.	Bit (mm)	Bit (mm)	Package size (mm)	Code
220USB25U	30*1/67*2	140*3	184x123x67	148527

*1 Bit only *2 Bit Holder only *3 Tool only



INCLUDES Impact Ball™ Torsion Bit * BitSize: 1-3/16"(30mm)

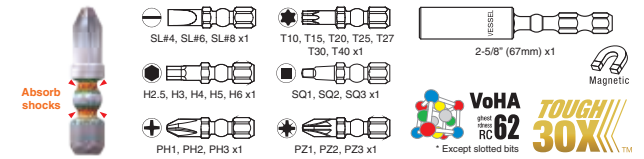

BALL GRIP™ Rechargeable Screwdriver <Higher Torque Model>

- Electric output 17.7lbf-in (2.0N·m), No-load speed 280rpm, Manual torque up to 88.5lbf-in (10.N·m)
- Electric power for quick tightening and Manual for final tightening.
- With High Brightness LED light.
- Built in USB Recharge Li-ion Battery (3.6V-800mAh).
- 6.35mm HEX shank.



Package



- Contents
- 220USB-1U x 1pc
 - Impact Ball Torsion Bit (PH2 x 90mm) x 1pc
 - USB Charging Cable (Micro USB Type B) (1m) x 1pc

Electric Output 17.7 lbf-in	No-load Speed 280 rpm	Manual Torque Up to 88.5 lbf-in
---------------------------------------	---------------------------------	-------------------------------------------

Model No.	Bit (mm)	Bit (mm)	Bit (mm)	Code
220USB1U	PH2	90*1	43	148514

*1 Bit *2 Tool Only

BALL GRIP™ Rechargeable Screwdriver <Higher Speed model>

- Electric output 3.5lbf-in (0.4N·m), No-load speed 1200rpm, Manual torque up to 88.5lbf-in (10.N·m)
- Electric power for quick tightening and Manual for final tightening.
- With High Brightness LED light.
- Built in USB Recharge Li-ion Battery (3.6V-800mAh).
- 6.35mm HEX shank.



Package



- Contents
- 220USB-S1U x 1pc
 - Impact Ball Torsion Bit (PH2 x 90mm) x 1pc
 - USB Charging Cable (Micro USB Type B) (1m) x 1pc

Electric Output 3.5 lbf-in	No-load Speed 1200 rpm	Manual Torque Up to 88.5 lbf-in
--------------------------------------	----------------------------------	-------------------------------------------

Model No.	Bit (mm)	Bit (mm)	Bit (mm)	Code
220USB-S1U	PH2	90*1	43	148515

*1 Bit *2 Tool Only

MEGADORA SCREWDRIVER

BALL GRIP SCREWDRIVER

SUPER CUSHION SCREWDRIVER

WOOD COMPO SERIES

FOR ELECTRONICS TOOLS/ USEFUL TOOLS

DRIVER SET SERIES

OTHER HAND TOOLS

L-WRENCH

IMPACT BALL

NECK-TORSION

DRYWALLER/ QB

INSERT BITS

POWER BITS

POWER BITS/ MAG CATCHER

DOUBLE-ENDED POWER BITS

NUT SETTERS

Bit Holder

PRECISION BITS

VESSEL's MEGADORA™ Series

MEGADORA IMPACTA™

Cam Rotation Mechanism

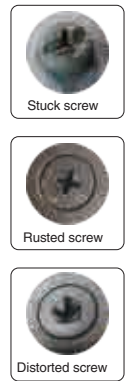

Non-Slip surface
For removing stuck, rusted, or stripped screws
Tang-Thru shank and steel cap with cam rotation mechanism

Reduce Cam-Out

Suitable for a variety of screws from machine screws to wood screws, and especially for car repairs as well as electric work, electronics assembly and general applications.



JAWSFIT
Bites into screw

MEGADORA™ Screwdriver

- Phillips JAWSFIT tip that firmly grips screws
- Useful knurled blade for quick and slipless driving



Model No.	Blade	Length (mm)	Tip	Shank Dia (mm)	Code
900S5575	5.5x75	5.5(3/16")	0.8	75(3")	30 175 125701
900S6100	6x100	6.0(1/4")	0.9	100(4")	34 210 125702
900S6150	6x150	6.0(1/4")	0.9	150(6")	34 260 125703
900S8150	8x150	8.0(5/16")	1.1	150(6")	36 275 125704
900P175	1x75	JAWSFIT. PH1	75	30 175	125705
900P2100	2x100	JAWSFIT. PH2	100	34 210	125706
900P2150	2x150	JAWSFIT. PH2	150	34 260	125707
900P3150	3x150	JAWSFIT. PH3	150	36 275	125708

Model No.	Blade	Length (mm)	Tip	Shank Dia (mm)	Code
903PZ175	1x75	PZ1	75	30 175	267254
903PZ2100	2x100	PZ2	100	34 210	267255
903PZ3150	3x150	PZ3	150	36 275	267256

MEGADORA IMPACTA™ Impact Driven Screwdriver



- Tang-Thru shank and steel cap with cam rotation mechanism
- High precision black point tip



Model No.	Blade	Length (mm)	Tip	Shank Dia (mm)	Code
980P2100	2x100	PH2	100(4")	34 213	125941
980P2150	2x150	PH2	150(6")	34 263	125942
980P3150	3x150	PH3	150(6")	36 278	125943

MEGADORA™ Tang-Thru Screwdriver



- Phillips JAWSFIT tip that firmly grips screws
- Tang-Thru shank with large steel cap
- With a hexagonal bolster for additional wrenching



Model No.	Blade	Length (mm)	Tip	Shank Dia (mm)	Code
930S5575	5.5x75	5.5(3/16")	0.8	75(3")	30 175 8 125711
930S6100	6x100	6.0(1/4")	0.9	100(4")	34 213 10 125712
930S6150	6x150	6.0(1/4")	0.9	150(6")	34 263 10 125713
930S8150	8x150	8.0(5/16")	1.1	150(6")	36 278 12 125714
930P175	1x75	JAWSFIT. PH1	75	30 176 8	125715
930P2100	2x100	JAWSFIT. PH2	100	34 213 10	125716
930P2150	2x150	JAWSFIT. PH2	150	34 263 10	125717
930P3150	3x150	JAWSFIT. PH3	150	36 278 12	125718

MEGADORA™ Thin Shank Screwdriver



- Precision type with 4 mm or smaller blade diameter
- High precision black point tip, which is unaffected by the plating thickness



Model No.	Blade	Length (mm)	Tip	Shank Dia (mm)	Code
910S375	3x75	3.0(1/8")	0.4	75(3")	21 153 125746
910S3100	3x100	3.0(1/8")	0.4	100(4")	21 178 125747
910S475	4x75	4.0(5/32")	0.5	75(3")	21 153 125748
910S4100	4x100	4.0(5/32")	0.5	100(4")	21 178 125749
910S4150	4x150	4.0(5/32")	0.5	150(6")	21 228 125750
910S4200	4x200	4.0(5/32")	0.5	200(8")	21 278 125751
910P075	0x75	PH0	75	21 153	125742
910P0100	0x100	PH0	100	21 178	125743
910P175	1x75	PH1	75	21 153	125744
910P1100	1x100	PH1	100	21 178	125745

MEGADORA™ Stubby Screwdriver



- Phillips JAWSFIT tip that firmly grips screws
- 1"(25mm)-long blade, ideal for works in a narrow place



Model No.	Blade	Length (mm)	Tip	Shank Dia (mm)	Code
920S625	6x25	6.4(1/4")	0.9	25(1")	36 75 125752
920P125	1x25	JAWSFIT. PH1	25	36 75	125753
920P225	2x25	JAWSFIT. PH2	25	36 75	125754

*Bulk

MEGADORA™ Insulated Screwdriver



- For protection against electric shock



Model No.	Blade	Length (mm)	Tip	Shank Dia (mm)	Code
960S575	0.8x5x75	5(3/16")	0.8	75(3")	30 177 125824
960S6100	1.0x6x100	6(1/4")	1	100(4")	34 212 125825
960S8150	1.2x8x150	8(5/16")	1.2	150(6")	36 277 125826
960P175	1x75	PH1	75	30 177	125821
960P2100	2x100	PH2	100	34 212	125822
960P3150	3x150	PH3	150	36 277	125823

Model No.	Blade	Length (mm)	Tip	Shank Dia (mm)	Code
960PS2100	PS2x100	PS2	100	34 212	125827
960PS3150	PS3x150	PS3	150	36 277	125828

MEGADORA™ Screwdriver Extra Long Type



- Phillips JAWSFIT tip that firmly grips screws
- Ideal for works in a deep place
- Useful for adjustment of automotive headlight and hose band removal
- Knurled guide sleeve to minimize run-out due to its long blade and ensure stable operation



Model No.	Blade	Length (mm)	Tip	Shank Dia (mm)	Code
900S6400	6x400	6.0(1/4")	0.9	400(16")	34 510 125709
900P2400	2x400	JAWSFIT. PH2	400	34 510	125710

MEGADORA™ Clip Remover

- Applicable for both large and small clips used in automobiles
- Smooth surface finish chrome plating to avoid making scratches on a painted metal parts
- Easy removing of door trim and wire binding clips by its optimum leverage angle in a narrow space



Model No.	Blade	Length (mm)	Tip	Shank Dia (mm)	Code
970CR6110	CR6x110	6	110(4 11/32")	30 215	121592
970CR71210	CR12-7x120	12-7	120(4 3/4")	34 230	122504

MEGADORA™ Chisel-Type Screwdriver



- Using special high quality steel for cold chisel use; 58HRC and pursuing abrasion resistance and cutting quality
- Reducing gripping fatigue by shock-absorbing Elastomer resin
- Less deformative large steel cap with carburizing and quenching



Model No.	Blade	Length (mm)	Tip	Shank Dia (mm)	Code
970C7100	7x100	7.0(9/32")	1.5	100(4")	34 213 125722
970C95120	9.5x120	9.5(3/8")	1.7	120(4 3/4")	36 248 125732

MEGADORA™ Hose Remover



Model No.	Blade	Length (mm)	Tip	Shank Dia (mm)	Code
970HRS130	HRSx130	130(5 1/8")	34	240	121593
970HRR89	HRRx89	89(3 1/2")	34	199	121594
970HRL89	HRLx89	89(3 1/2")	34	199	121595

BALL GRIP™ Screwdrivers

Reduce your fatigue by 20%

BALL GRIP Screwdriver can reduce fatigue by 20% compared to straight grip screwdrivers in the analysis of musculoskeletal system.

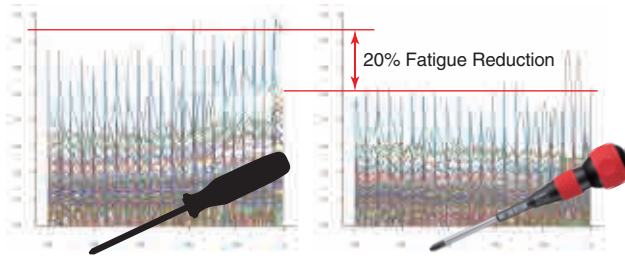

BALL GRIP™ Screwdriver

- Our original ergonomic BALL GRIP™ handle enables both quick and power driving, and reduces fatigue comparing to a traditional cylindrical handle.
- Transmits sufficient tightening force to screw
- Cushion grip color-coded by ⊕⊖
- High precision black point tip



Model No.	⊖	⊕	mm	mm	mm	mm	mm	mm	Code
220S5575	5.5x75	5.5(3/16")	0.8	75(3")	32	156	125351		
220S55100	5.5x100	5.5(3/16")	0.8	100(4")	32	181	125361		
220S55150	5.5x150	5.5(3/16")	0.8	150(6")	32	231	125362		
220S6100	6x100	6.0(1/4")	0.9	100(4")	41	200	125352		
220S6150	6x150	6.0(1/4")	0.9	150(6")	41	250	125353		
220S6200	6x200	6.0(1/4")	0.9	200(8")	41	300	125354		
220S6300	6x300	6.0(1/4")	0.9	300(12")	41	400	125363		
220S8150	8x150	8.0(5/16")	1.1	150(6")	41	250	125376		
220P175	⊕ 1x75	PH1	75	32	156	125355			
220P1100	1x100	PH1	100	32	181	125371			
220P1150	1x150	PH1	150	32	231	125372			
220P275	2x75	PH2	75	32	156	125375			
220P2100	2x100	PH2	100	41	200	125356			
220P2150	2x150	PH2	150	41	250	125357			
220P2200	2x200	PH2	200	41	300	125358			
220P2300	2x300	PH2	300	41	400	125359			
220P3150	3x150	PH3	150	41	250	125374			

BALL GRIP™ Tang-Thru Screwdriver

- Star-shaped steel cap for hammering
- Transmits sufficient tightening force to screw
- Cushion grip color-coded by ⊕⊖
- High precision black point tip



Model No.	⊖	⊕	mm	mm	mm	mm	mm	Code
230S5575	5.5x75	5.5(3/16")	0.8	75(3")	32	156	125311	
230S6100	6x100	6.0(1/4")	0.9	100(4")	41	200	125314	
230S6150	6x150	6.0(1/4")	0.9	150(6")	41	250	125315	
230P175	⊕ 1x75	PH1	75	32	156	125321		
230P2100	2x100	PH2	100	41	200	125324		
230P2150	2x150	PH2	150	41	250	125325		

BALL RATCHET™ Screwdriver

- 36-teeth gear ratchet to realize comfortable operation with fine turning
- Blade cover to prevent electrical short circuit and reduced or slim blade for convenience at an operation in a terminal block
- Using special alloy steel used for power tool bit, Fully hardened and Interchangeable blade



Model No.	⊖	⊕	mm	mm	mm	mm	Code
2200S6100	6x100	6.0(1/4")	0.8	100(4")	41	200	125395
2200S6150	6x150	6.0(1/4")	0.8	150(6")	41	250	125396
2200P2100	⊕ 2x100	PH2	100	41	200	125345	
2200P2150	2x150	PH2	150	41	250	125346	
2200P3150	3x150	PH3	150	41	250	125347	

BALL RATCHET™ Screwdriver Replacement Blade

- Using special alloy steel used for power tool bit, fully hardened
- Interchangeable when pulling out the ball part of the No.2200



Model No.	⊖	⊕	mm	mm	mm	mm	Code
2200BS6100	6x100	6.0(1/4")	0.8	100(4")	158	125397	
2200BS6150	6x150	6.0(1/4")	0.8	150(6")	208	125398	
2200BP2100	⊕ 2x100	PH2	100(4")	158	125348		
2200BP2150	2x150	PH2	150(6")	208	125349		
2200BP3150	3x150	PH3	150(6")	208	125350		

POINT

Smooth Operation [No.2200 Series]

This functionally enhanced BALL GRIP™ Screwdriver enables screw driving by simple repeated wrist or finger movements.



⚠ Electric insulation is not guaranteed. For safety purposes, shut off power before use.

BALL GRIP™ Interchangeable Ratchet Screwdriver

- 36-teeth gear ratchet to realize comfortable operation with fine turning.
- Bits are replaceable.
- With 1pc of bit

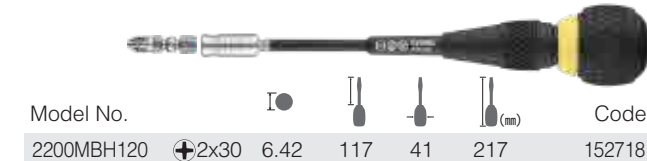

BALL GRIP™ Insulated Screwdriver

- High precision black point tip (black oxide finish)
- Easy identification of tip type by touching the end cap dent



Model No.	⊖	⊕	mm	mm	mm	mm	Code
200S575	5x0.8x75	5	0.8	75(3")	32	157	125841
200S6100	6x1.0x100	6	1.0	100(4")	41	200	125842
200S6150	6x1.0x150	6	1.0	150(6")	41	250	125843
200P175	⊕ 1x75	PH1	75	32	157	125844	
200P2100	2x100	PH2	100	41	200	125845	
200P2150	2x150	PH2	150	41	250	125846	
200P3150	3x150	PH3	150	41	250	125847	

BALL GRIP™ Screwdriver w/ Covered Shank

- Resin-covered shank. It prevents electrical short circuit.
- Transmits ample tightening force to screw.
- Cushion grip is marked ⊕⊖ for quick identification.

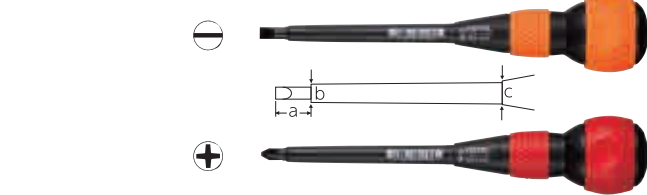

Model No.	⊖	⊕	mm	mm	mm	mm	mm	mm	Code
225S6100	6x100	6.0(1/4")	0.9	100(4")	200	14	8	10	125382
225S6150	6x150	6.0(1/4")	0.9	150(6")	250	14	8	10	125383
225P2100	⊕ 2x100	PH2	100(4")	200	14	8	10	125389	
225P2150	2x150	PH2	150(6")	250	14	8	10	125390	

BALL GRIP™ Interchangeable Ratchet Screwdriver 10PC. Bit Set

- 36-teeth gear ratchet to realize comfortable operation with fine turning.
- Bits are replaceable.
- With 10pc of bits and bit holding belt.

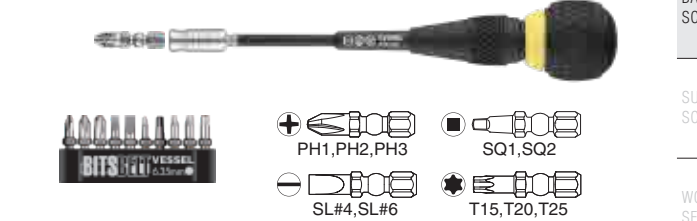

Model No. / Code	⊖	⊕	mm	mm	mm	mm
2200MBH120K01	6.42	117	41	217		
152719	⊕ PH1x30, PH2x30, PH3x30					
	⊖ SL4x30, SL6x30					
	⚙ T15x30, T20x30, T25x30					
	⊖ SQ1x30, SQ2x30					

BALL GRIP™ Tang-Thru Screwdriver w/Ceramic Ball

- Incorporating a ceramic ball that prevents electricity from being conducted
- Using zirconia ceramic that is highest strength, stiffness, and abrasion resistance among ceramics
- The large steel cap for easy hammering
- High precision black point tip



Model No.	⊖	⊕	mm	mm	mm	mm	mm	Code
250S6100	6x100	6.0(1/4")	0.9	100(4")	41	200	112105	
250S6150	6x150	6.0(1/4")	0.9	150(6")	41	250	112106	
250S8150	8x150	8.0(5/16")	1.1(3/64")	150(6")	41	250	112109	
250P2100	⊕ 2x100	PH2	100	41	200	112107		
250P2150	2x150	PH2	150	41	250	112108		
250P3150	3x150	PH3	150	41	400	112110		

POINT

Ceramic ball blocks electricity [No.250]

It can be used for various works of electrical and mechanical equipment as a screwdriver that can be "hit with a hammer and used for electricity-related work."



BALL GRIP™ Tethered Screwdriver

- 5"(125mm)-long blade that can reach deep in distribution boards
- Easy picking from a working waist bag Turning sleeve for smooth operation
- Connection wire to attach Slim Lanyard Cord (No.SC-90)
- High precision black point tip



Model No.	Bit	Length (mm)	Code
210S6125	6x125	6.0(1/4")	0.9 125(5") 41 225 125577
210P2125	2x125	PH2	125 41 225 125576

Anti-drop Slim Cord

- Cord to tether screwdrivers from dropping
- Tangle-free sleeve to prevent from being caught and stuck



Model No.	Mounted load	Length	Code
SC90	500g or less	482 (maximum length 1500) mm	125405

"NEON" Screwdriver

- Glow-in-the-dark type.
- High precision black point tip.

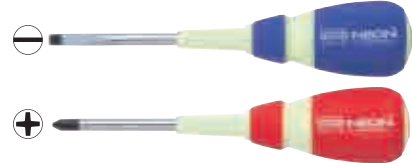

Model No.	Bit	Length (mm)	Code
265S6100	6x100	6.0(1/4")	0.9 100(4") 185 125561
265S6150	6x150	6.0(1/4")	0.9 150(6") 235 125562
265P2100	2x100	PH2	100(4") 185 125563
265P2150	2x150	PH2	150(6") 235 125564

BALL GRIP™ Interchangeable Screwdriver

- Slotted tip used for quick connection terminal such as outlet and frequently-used +2 are combined into one bit.



Model No. / Code	Set Contents
220W62	BALL GRIP™ Interchangeable Drive Handle
233071	6/2 x110 Carded

BALL GRIP™ Interchangeable Screwdriver Set

- Convenient set with +1, +3, slotted tip used for quick connection terminal such as outlet, frequently-used +2, and Pz2 and Pz3 widely used for European furniture, appliances, sports equipments, and more



Model No. / Code	Set Contents
220W3	BALL GRIP™ Interchangeable Drive Handle
233072	1/3 x110, 6/2 x110 Carded
	PZ2/PZ3 x110

Combi Plus Screwdriver

- Three sizes are combined into one bit. Can be used for most of Phillips screws commonly used.



Model No. / Code	Set Contents
220W123	BALL GRIP™ Interchangeable Drive Handle
233073	1•3/2 x110 Carded

GEL GRIP Screwdrivers

GEL FUNCTION

GEL GRIP is ideal for a heavy load on the palm, such as working for long wood screws.



SUPER CUSHION™ Screwdriver

- "Super Cushion" grip fits your hand perfectly
- Anti-corrosion black chrome plated blade



Model No.	Bit	Length (mm)	Code
700S5575	5.5x75	5.5(3/16")	0.8 75(3") 29 182 125211
700S6100	6x100	6.0(1/4")	0.9 100(4") 32 215 125212
700S6150	6x150	6.0(1/4")	0.9 150(6") 32 265 125213
700S8150	8x150	8.0(5/16")	1.1 150(6") 34 275 125214
700P175	1x75	PH1	75 29 182 125215
700P2100	2x100	PH2	100 32 215 125216
700P2150	2x150	PH2	150 32 265 125217
700P3150	3x150	PH3	150 34 275 125218

Cushion Grip Stubby Screwdriver

- Anti-corrosion black chrome plated blade
- Ideal for working in a narrow place



Model No.	Bit	Length (mm)	Code
720S615	6x15	6.0(1/4")	0.9 15(19/32") 35 68 125221
720P115	1x15	PH1	15(19/32") 35 68 125222
720P215	2x15	PH2	15(19/32") 35 68 125223

*Bulk

SUPER CUSHION™ Tang-Thru Screwdriver

- "Super Cushion" grip fits your hand perfectly
- Star-shaped steel cap for hammering
- Anti-corrosion black chrome plated blade



Model No.	Bit	Length (mm)	Code
730S5575	5.5x75	5.5(3/16")	0.8 75(3") 29 182 125231
730S6100	6x100	6.0(1/4")	0.9 100(4") 32 215 125232
730S6150	6x150	6.0(1/4")	0.9 150(6") 32 265 125233
730S8150	8x150	8.0(5/16")	1.1 150(6") 34 276 125234
730P175	1x75	PH1	75 29 182 125235
730P2100	2x100	PH2	100 32 215 125236
730P2150	2x150	PH2	150 32 265 125237
730P3150	3x150	PH3	150 34 276 125238

Cushion Grip TORX Screwdriver

- Optimal for fastening screws in precision fields.
- Non-electrolytic plating, keeping the precise tip quality.
- Cushion grip fitting comfortably in a hand.
- Also good for tamper-proof TORX screws (except T5 and T6).



Model No.	Bit	Length (mm)	Code
640T540	T5	1.42	40(1 37/64") 20.5 126 123561
640T640	T6	1.69	40(1 37/64") 20.5 126 123562
640T7H40	T7H	1.97	40(1 37/64") 20.5 126 123563
640T8H40	T8H	2.30	40(1 37/64") 20.5 126 123564
640T9H40	T9H	2.48	40(1 37/64") 20.5 126 123565

TORX® is a registered trademark of Acument™ Intellectual Properties, LLC (USA). VESSEL has a manufacturing license in Japan and selling same to the world.

Cushion Grip Interchangeable Stubby Screwdriver

- Stubby type suited for working in cramped places.
- Slotted tip used for quick connection terminal such as outlet and frequently-used 2 are combined into one bit.



Model No. / Code	Set Contents
270BW62	Bit Interchangeable Cushion Stubby Grip
233075	6/2 x110mm Carded

Cushion Grip Interchangeable Stubby Screwdriver

- Stubby type suited for working in cramped places.
- Three sizes are combined into one bit. Can be used for most of Phillips screws commonly used.



Model No. / Code	Set Contents
270BW123	Bit Interchangeable Cushion Stubby Grip
233076	1•3/2 x45mm Carded

WOOD-COMPO™ Ratchet SETS

NON-SLIP with Oil or Grease

You lose only 3% of torque even with oily or greasy hands. WOOD COMPO improves your performance such as working for car maintenance and ironwork.



WOOD-COMPO™ Swivel Socket Wrench Set

1/4"sq. (6.35mm) 21pcs.



Model No. / Code	Set Contents
HRW2004MSW	Wood-compo swivel ratchet handle 1/4"sq. (6.35mm)
162102	Extension bar Overall length 55mm 1/4"sq. (6.35mm)
	Extension bar Overall length 150mm 1/4"sq. (6.35mm)
	Quick spinner 1/4"sq. (6.35mm)
	Hex key wrench: H2.5, 3, 4, 5, 6, 8mm
	1/4"sockets: H5, 5.5, 6, 7, 8, 9, 10, 11, 12, 13, 14mm

WOOD-COMPO™ Swivel Socket Wrench Set

3/8"sq. (9.5mm) 16pcs.



Model No. / Code	Set Contents
HRW3005MSW	Wood-compo swivel ratchet handle 3/8"sq. (9.5mm)
162103	Extension bar Overall length 55mm 3/8"sq. (9.5mm)
	Quick spinner 3/8"sq. (9.5mm)
	Deep socket 3/8"sq. (9.5mm): H8, 10, 12, 14mm
	3/8"sockets: H8, 10, 12, 13, 14, 17, 19, 21, 24mm

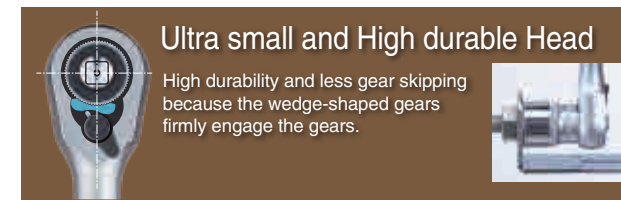

WOOD-COMPO™ Ratchet Handle

- High durability and less gear skipping by firmly engaging wedge-shaped gears
- Reliable operation as the hand firmly holds the grip from the moment you start fastening

1/4"sq. (6.35mm)



Model No.	□	⌘	⌚	⌘	⌘(mm)	Code
HRH2W	6.35(1/4")	20	20	30	145	162004

3/8"sq. (9.5mm)



Model No.	□	⌘	⌚	⌘	⌘(mm)	Code
HRH3W	9.5(3/8")	25	27	30	180	162005

WOOD-COMPO™ Socket Wrench Set

1/4"sq.(6.35mm) 36pcs.



Model No. / Code	Set Contents
HRW2001MW	Wood-compo ratchet handle 1/4"sq.(6.35mm)
162001	Wood-compo stubby handle 1/4"sq.(6.35mm)
	Universal socket adaptor 1/4"sq.(6.35mm)
	Extension bar Overall length 100mm 1/4"sq.(6.35mm)
	Bit socket adaptor 1/4"sq.↔1/4"hex.
	1/4"sockets: 4, 4.5, 5, 5.5, 6, 7, 8, 9, 10, 11, 12, 13, 14mm
	Bits: ⊖ 4, 6, ⊕ 1, 2, 3, H1.5, H2, H2.5, H3, H4, H5, T10, T15, T20, T25, T27, T30, T40

WOOD-COMPO™ Socket Wrench Set

1/4"sq.(6.35mm)/3/8"sq.(9.5mm) 36pcs.



Model No. / Code	Set Contents
HRW2303MW	Wood-compo ratchet handle 3/8"sq. (9.5mm)
162003	Wood-compo spinner handle 1/4"sq. (6.35mm)
	Universal socket adaptor 3/8"sq. (9.5mm)
	Extension bar Overall length 150mm 1/4"sq. (6.35mm)
	Bit socket adaptor 1/4"sq.↔1/4"hex.
	1/4"sockets: 4, 4.5, 5, 5.5, 6, 7, 8mm
	3/8"sockets: 10, 11, 12, 13, 14, 17, 19, 21, 22mm
	Bits: ⊖ 4, 6, ⊕ 1, 2, 3, H3, H4, H5, H6, T10, T15, T20, T25, T30, T40

WOOD-COMPO™ Socket Wrench Set

3/8"sq.(9.5mm) 16pcs.



Model No. / Code	Set Contents
HRW3002MW	Wood-compo ratchet handle 3/8"sq.(9.5mm)
162002	Universal socket adaptor 3/8"sq.(9.5mm)
	Sliding T-shaped handle 3/8"sq.(9.5mm)
	Extension bar Overall length 150mm 3/8"sq.(9.5mm)
	Extension bar Overall length 75mm 3/8"sq.(9.5mm)
	3/8" sockets: 7, 8, 10, 11, 12, 13, 14, 17, 19, 21, 22mm

WOOD-COMPO™ Screwdrivers

NON-SLIP with Oil or Grease

You lose only 3% of torque even with oily or greasy hands. WOOD COMPO improves your performance such as working for car maintenance and ironwork.



WOOD-COMPO™ Screwdriver

- Extraordinary non-slip grip; Secure working efficiency even with oily hands
- Wood-composite material, reproducing the natural material texture
- Anti-corrosion black chrome plated blade



Model No.	⊖	⊕	⊖	⊕	⊖	⊕	⊖	⊕	(mm)	Code
300S5575	⊖ 5.5x75	5.5(3/16")	0.8	75(3")	30	182	120021			
300S6100	⊖ 6x100	6.0(1/4")	0.9	100(4")	32	215	120022			
300S6150	⊖ 6x150	6.0(1/4")	0.9	150(6")	32	265	120027			
300S8150	⊖ 8x150	8.0(5/16")	1.1	150(6")	35	275	120023			
300P175	⊕ 1x75	PH1	75	30	182	120024				
300P2100	⊕ 2x100	PH2	100	32	215	120025				
300P2150	⊕ 2x150	PH2	150	32	265	120029				
300P3150	⊕ 3x150	PH3	150	35	275	120026				

WOOD-COMPO™ Screwdriver (Stubby Type)

- Stubby type, which is convenient for tightening screws in cramped spaces.
- Wood-composite resin, reproducing the natural material texture.
- Rust-resistant black chrome plating shank.



Model No.	⊖	⊕	⊖	⊕	⊖	⊕	⊖	⊕	(mm)	Code
320S615	⊖ 6x15	6.0(1/4")	0.9	15(19/32")	35	68	120035			
320P215	⊕ 2x15	PH2	15(19/32")	35	68	120037				

WOOD-COMPO™ Tang-Thru Screwdriver

- Extraordinary non-slip grip; Secure working efficiency even with oily hands
- Star-shaped steel cap for hammering
- Anti-corrosion black chrome plated blade



Model No.	⊖	⊕	⊖	⊕	⊖	⊕	⊖	⊕	(mm)	Code
330S5575	⊖ 5.5x75	5.5(3/16")	0.8	75(3")	30	183	120041			
330S6100	⊖ 6x100	6.0(1/4")	0.9	100(4")	32	217	120042			
330S6150	⊖ 6x150	6.0(1/4")	0.9	150(6")	32	267	120043			
330S8150	⊖ 8x150	8.0(5/16")	1.1	150(6")	35	277	120044			
330P175	⊕ 1x75	PH1	75	30	183	120045				
330P2100	⊕ 2x100	PH2	100	32	217	120046				
330P2150	⊕ 2x150	PH2	150	32	267	120047				
330P3150	⊕ 3x150	PH3	150	35	277	120048				

WOOD-COMPO™ Torx Screwdriver

- Extraordinary non-slip grip; Secures working efficiency even with oily hands
- Wood-composite material, reproducing the natural material texture
- Non-electrolytic nickel plating, keeping the precise tip quality
- Applicable for both standard and tamper-proof Torx screws



Model No.	⊖	⊕	⊖	⊕	⊖	⊕	⊖	⊕	(mm)	Code
340T10H80	⊖ T10H	2.72	80(3 1/8")	30	188	120081				
340T15H80	⊖ T15H	3.26	80(3 1/8")	30	188	120082				
340T20H120	⊖ T20H	3.84	120(4 3/4")	30	228	120083				
340T25H120	⊖ T25H	4.40	120(4 3/4")	32	236	120084				
340T27H120	⊖ T27H	4.96	120(4 3/4")	32	236	120085				
340T30H120	⊖ T30H	5.49	120(4 3/4")	35	246	120086				
340T40H120	⊖ T40H	6.60	120(4 3/4")	35	246	120087				

TORX® is a registered trademark of Acument™ Intellectual Properties, LLC (USA). VESSEL has a manufacturing license in Japan and selling same to the world.

WOOD-COMPO™ Socket Screwdriver

- Extraordinary non-slip grip; Secures working efficiency even with oily hands
- Wood-composite material, reproducing the natural material texture
- Black oxide coated socket
- Anti-corrosion chrome plated hexagonal shank for additional wrenching



Model No.	⊖	⊕	⊖	⊕	⊖	⊕	⊖	⊕	(mm)	Code
380AF5125	⊖ A/F 5x125	5	125(5")	5.0(3/16")	30.0	224	120091			
380AF55125	⊖ A/F 5.5x125	5.5	125(5")	5.0(3/16")	30.0	224	120092			
380AF7125	⊖ A/F 7x125	7	125(5")	5.0(3/16")	30.0	224	120093			
380AF8125	⊖ A/F 8x125	8	125(5")	5.0(3/16")	32.0	233	120094			
380AF10125	⊖ A/F 10x125	10	125(5")	7.0(9/32")	32.0	233	120095			
380AF12125	⊖ A/F 12x125	12	125(5")	7.0(9/32")	32.0	233	120096			
380AF13125	⊖ A/F 13x125	13	125(5")	7.0(9/32")	32.0	233	120097			
380AF14125	⊖ A/F 14x125	14	125(5")	7.0(9/32")	32.0	233	120098			

Powerful Tang-Thru Screwdriver

- Wooden handle and Tang-Thru shank with thick end cap.
- Large and long grip comfortable to hold.
- Black point tip.



Model No.	⊖	⊕	⊖	⊕	⊖	⊕	⊖	⊕	(mm)	Code
100S5575	⊖ 5.5x75	5.5(3/16")	0.8	75(3")	27.0	182	111051			
100S6100	⊖ 6x100	6.0(1/4")	0.9	100(4")	30.5	223	111052			
100S6300	⊖ 6x300	6.0(1/4")	0.9	300(12")	30.5	423	111061			
100S8150	⊖ 8x150	8.0(5/16")	1.1	150(6")	34.0	294	111053			
100P175	⊕ 1x75	PH1	75	27.0	182	111054				
100P2100	⊕ 2x100	PH2	100	30.5	223	111055				
100P2300	⊕ 2x300	PH2	300	30.5	423	111066				
100P3150	⊕ 3x150	PH3	150	34.0	294	111056				

Electronic Tools

Micro Screwdriver

- Smooth rotating end cap for quick turning
- High precision black point tip



Model No.	⊖	⊕	⊖	⊕	⊖	⊕	⊖	⊕	(mm)	Code
9900ES1850	⊖ 1.8x50	1.8(1/16")	0.25	50	10	145	125621			
9900ES2575	⊖ 2.5x75	2.5(3/32")	0.35	75	10	170	125622			
9900ES3100	⊖ 3x100	3(1/8")	0.45	100	10	195	125623			
9900ES3150	⊖ 3x150	3(1/8")	0.45	150	10	245	125624			
9900EP0075	⊕ 00x75	PH00	75	10	170	125625				
9900EP0100	⊕ 0x100	PH0	100	10	195	125626				
9900EP0150	⊕ 0x150	PH0	150	10	245	125627				

Micro Screwdriver 3PC. Set

- 2 types of set recommended to the purpose of work in precision field
- Sets with frequently used sizes
- For adjustment and repair of precision devices, electric devices, glasses, watches, and more



Model No. / Code	Set Contents
9902E	Micro Screwdriver
125636	⊖ 1.8x50
	⊕ 00x75, 0x100

Package size: 235x70x15mm



Model No. / Code	Set Contents
9903E	Micro Screwdriver
125637	⊖ 1.8x50, 2.5x75
	⊕ 00x75

Package size: 235x70x15mm

Precision Ceramic Adjuster

- Uses a zirconia ceramics tip, non-inductive magnetic substance.
- Optimum for coil and trimmer adjustments.
- For the adjustment of electronic parts, such as audio instruments, computers, telecommunication devices, electronics components, and electric components.



Model No.	⊖	⊕	⊖	⊕	⊖	⊕	⊖	⊕	(mm)	Code
9000ES0930	⊖ 0.9x30	0.9(1/32")	0.4	30(1 3/64")	10	125	125641			
9000ES1330	⊖ 1.3x30	1.3(3/64")	0.4	30(1 3/64")	10	125	125642			
9000ES1830	⊖ 1.8x30	1.8(1/16")	0.4	30(1 3/64")	10	125	125643			
9000ES2630	⊖ 2.6x30	2.6(7/64")	0.4	30(1 3/64")	10	125	125644			
9000ES3415	⊖ 3.4x15	3.4(9/64")	0.5	30(1 3/64")	10	125	125645			
9000EP030	⊕ 0x30	PH0	30(1 3/64")	10	125	125646				
9000EP1730	⊕ 1.7x30	Width 1.7(1/16")	30(1 3/64")	10	125	125647				

Unique Hand Tools

Ratchet Rivet Gun

- Can caulk blind rivets easily with one hand.
- Easily caulks 4.8 mm steel rivets that were difficult to use with existing manual riveters.



Model No. / Code	Set Contents
RG95	Accessories Nose piece 2.4, 3.2, 4.0, 4.8mm
621310	Nose piece wrench A/F10mm
	Body length 230mm

Thread Thru Stud Bolt Wrench

- Works with continuous thread studs, cut bolts and hanger bolts.
- Can be used 2 ways: Straight for tightening, or bent for fast turning.
- Can be used from halfway point with long hanger bolts.
- Lightweight, compact and easy to carry.



Model No.	Thread part	⊖	⊕	⊖	⊕	Code
ZW3	3/8	32(1 17/64")	20(25/32")	140(5 33/64")	621320	
ZW4	1/2	32(1 17/64")	20(25/32")	140(5 33/64")	621321	

POINT



Ratchet Rivet Gun
Allows you to caulk blind rivets easily with one hand



Thread Thru Stud Wrench
Dedicated for installing a full-thread bolt. It can be bent to turn a bolt quickly.

VESSEL Screwdriver SETS

220USB SERIES

220USB SERIES

MEGADORA SCREWDRIVER

MEGADORA SCREWDRIVER

BALL GRIP SCREWDRIVER

BALL GRIP SCREWDRIVER

SUPER CUSHION SCREWDRIVER

SUPER CUSHION SCREWDRIVER

WOOD COMPO SERIES

WOOD COMPO SERIES

FOR ELECTRONICS TOOLS/ USEFUL TOOLS

FOR ELECTRONICS TOOLS/ USEFUL TOOLS

DRIVER SET SERIES

DRIVER SET SERIES

OTHER HAND TOOLS

OTHER HAND TOOLS

L-WRENCH

L-WRENCH

IMPACT BALL

IMPACT BALL

NECK-TORSION

NECK-TORSION

DRYWALLER/ QB

DRYWALLER/ QB

INSERT BITS

INSERT BITS

POWER BITS

POWER BITS

POWER BITS/ MAG CATCHER

POWER BITS/ MAG CATCHER

DOUBLE-ENDED POWER BITS

DOUBLE-ENDED POWER BITS

NUT SETTERS

NUT SETTERS

Bit Holder

Bit Holder

PRECISION BITS

PRECISION BITS

MEGADORA™ JAWSFIT® Screwdriver 8PC. Set



Model No. / Code	Set Contents
9008EVA	No.900 MEGADORA™ Screwdriver
121587	⊖ 5.5x75, 6x150, 8x150 ⊕ 1x75, 2x150, 3x150
	No.920 MEGADORA™ Stubby Screwdriver
	⊖ 6x25, ⊕ 2x25

MEGADORA™ JAWSFIT® Tang-Through Screwdriver 8PC. Set



Model No. / Code	Set Contents
9308EVA	No.930 MEGADORA™ Tang-Through Screwdriver
121588	⊖ 5.5x75, 6x150, 8x150 ⊕ 1x75, 2x150, 3x150
	No.920 MEGADORA™ Stubby Screwdriver
	⊖ 6x25 ⊕ 2x25

MEGADORA IMPACTA™ Assorted Screwdriver 8PC. Set



Model No. / Code	Set Contents
980MIXEVA	No.980 MEGADORA IMPACTA™ Screwdriver
121589	⊕ 2x100, 2x150, 3x150
	No.900 MEGADORA™ Screwdriver
	⊖ 8x150, ⊕ 1x75
	No.930 MEGADORA™ Tang-Through Screwdriver
	⊖ 5.5x75
	No.920 MEGADORA™ Stubby Screwdriver
	⊖ 6x25, ⊕ 2x25

MEGADORA™ Screwdriver 6PC. Set



Model No. / Code	Set Contents
9006PB	No.900 MEGADORA™ Screwdriver
122500	⊖ 5.5x75, 6x100, 8x150 ⊕ 1x75, 2x100, 3x150

MEGADORA™ Insulated Screwdriver 6PC. Set



Model No. / Code	Set Contents
9606EVA	No.960 MEGADORA™ Insulated Screwdriver
150906	⊖ 5x75, 6x100, 8x150 ⊕ 1x75, 2x100, 3x150

MEGADORA™ Chisel/ Clip Remover/ Hose Remover Mix 6PC. Set



Chisel-Type Screwdriver

Model No. / Code	Set Contents
9706EVA	No.970 MEGADORA™ Chisel-Type Screwdriver
121598	9.5x120
	No.970 MEGADORA™ Clip Remover
	CR6x110, CR7•12x120
	No.970 MEGADORA™ Hose Remover
	HRSx130, HRRx89, HRLx89

MEGADORA IMPACTA™ Screwdriver 2PC. Set



Model No. / Code	Set Contents
9802SC	No.980 MEGADORA IMPACTA™ Screwdriver
122503	⊕ 2x100, 3x150

MEGADORA™ Clip Remover 2PC. Set



Model No. / Code	Set Contents
970CR2SC	No.970 MEGADORA™ Clip Remover
121596	CR6x110, CR7•12x120

MEGADORA™ Hose Remover 3PC. Set



Model No. / Code	Set Contents
970HR3PB	No.970 MEGADORA™ Hose Remover
121597	HRSx130, HRRx89, HRLx89

WOOD-COMPO™ Non-Slip Tang-Through Screwdriver 8PC. Set



Model No. / Code	Set Contents
3308EVA	No.330 WOOD-COMPO™ Tang-Through Screwdriver
150902	⊖ 5.5x75, 6x150, 8x150 ⊕ 1x75, 2x150, 3x150
	No.320 WOOD-COMPO™ Stubby Screwdriver
	⊖ 6x15, ⊕ 2x15

WOOD-COMPO™ Non-Slip Tamper-proof Torx Screwdriver 7PC. Set



Model No. / Code	Set Contents
3407EVA	No.340 WOOD-COMPO™ Tamper-proof Torx Screwdriver
150903	⊗ T10x120H, T15Hx120, T20Hx120, T25Hx120 T27Hx120, T30Hx120, T40Hx120

WOOD-COMPO™ Non-Slip Hex Nut Driver 8PC. Set



Model No. / Code	Set Contents
3808EVA	No.380 WOOD-COMPO™ Hex Nut Driver
150904	⊖ A/F 5x125, A/F 5.5x125, A/F 7x125, A/F 8x125 A/F 10x125, A/F 12x125, A/F 13x125, A/F 14x125

WOOD-COMPO™ Non-Slip Screwdriver 6PC. Set



Model No. / Code	Set Contents
3006CS	Wood-Compo™ Screwdriver
150901	⊖ 5.5x75, 6x100, 8x150 ⊕ 1x75, 2x100, 3x150

BALL RATCHET™ Screwdriver 5PC. Set



Model No. / Code	Set Contents
22005EVA	No.2200 Ball Ratchet™ Screwdriver
121590	⊖ 6x100, 6x150 ⊕ 2x100, 2x150, 3x150

⚠ Electric insulation is not guaranteed. For safety purposes, shut off power before use.

BALL RATCHET™ Screwdriver 2PC. with 3PC. Replacement Blade Set



Model No. / Code	Set Contents
22002N3EVA	No.2200 Ball Ratchet™ Screwdriver
121591	⊖ 6x100 ⊕ 2x100
	No.2200B Replacement Blade
	⊖ 6x150, ⊕ 2x150, 3x150

BALL GRIP™ Screwdriver 4PC. Set



Model No. / Code	Set Contents
2204CS	Ball Grip™ Screwdriver
152720	⊖ 5.5x75, 6x100 ⊕ 1x75, 2x100

BALL GRIP™ Insulated Screwdriver 5PC. Set



Model No. / Code	Set Contents
2005PBU	Ball Grip™ Insulated Screwdriver
150905	⊖ 5x75, 6x100 ⊕ 1x75, 2x100, 3x150

Other Hand Tools

Plastic Head Hammer

- Soft durable plastic head. Does not damage workpieces.
- Replacement head ia available as option in a box.
- Replacement head of 1/2, 1 and 1 1/2 sizes is also available in 2-pc pre-carded package.



Model No.	Size	Length	Head Diameter	Head Length (mm)	Code
H7014	1/4	280	19.5	66.5	142001
H7012	1/2	280	25	82	142002
H7010	1	295	31.3	108	142003
H70112	1 1/2	325	37.6	125.5	142004
H7020	2	350	45.4	139	142005

Handles are not separately sold.

Replacement head for No.70

Model No.	Model No.	Set Contents	Inner Ctn.	Package size (mm)	Code
RH7014	Head 70x1/4	1/4	20	85x102x20	142011
RH7012	Head 70x1/2	1/2	20	110x132x27	142012
RH7010	Head 70x1	1	20	130x155x35	142013
RH70112	Head 70x1 1/2	1 1/2	20	80x185x42	142014
RH7020	Head 70x2	2	20	100x225x48	142015

Gel Grip Hammer (Plastic Head)

- Gel resin grip drastically absorbs the shocks by hammer blows to your palm. Alleviates the strain on your wrist.
- Slip resistance grip design of elastomer resin.
- Excellent balance between both heads, ensuring firm feeling of hammering.
- Hammer heads are screwed on and replaced easily. Replacement head is available as option.



Model No.	Size	Length	Head Diameter	Head Length (mm)	Weight (g)	Code
H7610	1	315	32	120	430	142082

Replacement Head for No.77 (Rubber Head)

Model No.	Model No.	Set Contents	Inner Ctn.	Package size (mm)	Code
RH7610	77-10H	1Lb	20	130x155x35	142131

※Apply hammer Gel Grip Hammer No.76-10 No.77-10 Plastic Head Hammer No.70-1

Gel Grip Hammer (Rubber/Plastic Head)

- Gel resin grip drastically absorbs the shocks by hammer blows to your palm. Alleviates the strain on your wrist.
- Slip resistance grip design of elastomer resin.
- Excellent balance between both heads, ensuring firm feeling of hammering.
- Hammer heads are screwed on and replaced easily. Replacement head is available as option.
- The hammer heads are screwed on and replaced easily. Rubber head is available as option. Rubber head is of light gray color, which does not cause color staining to the object.



Model No.	Size	Length	Head Diameter	Head Length (mm)	Weight (g)	Code
H7710	1	315	32	120	430	142091

Replacement Head for No.77 (Rubber Head)

Model No.	Model No.	Set Contents	Inner Ctn.	Package size (mm)	Code
RH7710	77-10H	1Lb	20	130x155x35	142121

※Apply hammer Gel Grip Hammer No.77-10 Cannot be used for plastic hammer No.70-1.

Flat-shaped Ratchet Screwdriver (straight type)

- 18mm thin head ratchet screwdriver.
- Magnetized bits (Overall length: 18mm) for cramped space included.
- 2pcs of bit can be stored in the handle. With a hole for hanging.
- High-precision ratchet gear mechanism realizes ideal fastening.



Model No. / Code	Set Contents
TX76U	Flat-shaped Ratchet Screwdriver (Straight type)
251237	Bits ⊕1, ⊕2, ⊕2, ⊕3, ⊖4, ⊖6, H2.5, H3, H4, H5, H6×18mm, Bit holder

Flat-shaped Ratchet Screwdriver (Angle Type)

- 18mm thin head ratchet screwdriver.
- Magnetized bits (Overall length: 18mm) for cramped space included.
- 2pcs of bit can be stored in the handle. With a hole for hanging.
- High-precision ratchet gear mechanism realizes ideal fastening.



Model No. / Code	Set Contents
TX79U	Flat-shaped Ratchet Screwdriver (Angle Type)
251238	Bits ⊕1, ⊕2, ⊕2, ⊕3, ⊖4, ⊖6, H2.5, H3, H4, H5, H6×18mm, Bit holder

Wire Stripper

- Lightweight (100g), compact handy type.
- Diamond finely polished blade for precision stripping.
- AWG-mm-mm conversion table on the grip.



Model No.	Model No.	Color	Overall length (mm)	Weight (g)	Code
WS3500E1E	3500E-1E	Red	155	100	141036
WS3500E2E	3500E-2E	Yellow	155	100	141037

Package size...220x75x13mm

Wire Stripper

- True circle shape. No damage on wires.
- Different colors adopted for instant awareness of holding position.
- Thread cutters for small screws or bolts.
- Anti-drop cord can be attached.
- AWG-mm-mm2 conversion table on the cushion grip.



Model No.	Model No.	Color	Overall length (mm)	Weight (g)	Code
WS3500E3	3500E-3E	Red/Black	163	107	141013
WS3500E4	3500E-4E	Yellow/Black	163	107	141014

Package size...220x75x13mm

	AWG	12	14	16	18	20	22	24
3500E-1	Solid wire(mm)	2.0	1.6	1.3	1.0	0.8	0.65	0.5
3500E-3	Stranded wire(mm)	3.3	2.0	1.3	0.8	0.5	0.3	0.2
3500E-2	AWG	18	20	22	24	26	28	30
3500E-4	Solid wire(mm)	1.0	0.8	0.65	0.5	0.4	0.3	0.25
	Stranded wire(mm)	0.8	0.5	0.3	0.2	0.13	0.08	0.05

* Some Teflon wires are not suitable.

Wire Stripper

- Nimble and cleanly strips off sheathing in a single operation.
- Can be used with wiring for TV, radio, home appliances, electrical work, automotive circuits, telephones, etc.
- With a strip gauge.



Model No.	Model No.	Wire diameter and nominal sectional area	Handle color	Overall length (mm)	Weight (g)	Code
WS3000A	3000A	For solid wire 0.5/1.2/1.6/2.0mm	Green	170	350	141001
WS3000B	3000B	For solid wire 1.0/1.6/2.0/2.6/3.2mm	Red	170	350	141002
WS3000C	3000C	For stranded wire 0.9/1.25/2.0/3.5/5.5mm	Black	170	350	141000

Package size...220x75x13mm

Wire Stripper Blade

Model No.	Model No.	Applicable wire stripper	Wire diameter and nominal sectional area	Code
WB001	WB-001	⊕2×36	3000A, 300001 For solid wire	141071
WB002	WB-002	⊕3×36	3000B, 300002 For solid wire	141072
WB003	WB-003	⊖8×36	3000C, 300005 For stranded wire	141073

Package size...195x30x15mm

Manual Impact Driver with Cushion Grip Handle 5/16" Hex & 1/2" SQ Drive Set

- One-touch switching of the rotation direction.
- Soft non-slip resin handle, comfortable to grip. Designed for less shock on hands.
- For heavy-duty use.
- If the bit adapter is detached, a 12.7 mm socket can be attached.
- Bit insertion part ⌀8mm



Model No. / Code	Set Contents	Package size (mm)
ID240001	Bits ⊕10, ⊕2, ⊕3, ⊕4×36, ⊕2, ⊕3×80	220x73x80
246051	Body length 176mm dia. 37.5mm	

Manual Impact Driver 5/16" Hex & 1/2" SQ Drive Set

- Effective for very tight fastening and loosening rusted screws.
- Suited for automobile maintenance, and assembly and disassembly of machinery and equipment.
- For heavy-duty use.
- If the bit adapter is detached, a 12.7 mm socket can be attached.
- Bit insertion part ⌀8mm



Model No. / Code	Set Contents	Package size (mm)
ID250001	Bits ⊕10, ⊕2, ⊕3, ⊕4×36	220x73x80
246001	Body length 166mm dia. 32mm	

INSERT BIT 5/16" Hex

Model No.	Set Content	Pack QTY	Code
C51P236G	⊕2x36G for Manual Impact Driver	10 Bulk	431041
C51P280G	⊕2x80G for Manual Impact Driver	10 Bulk	431042
C51P336E	⊕3x36E for Manual Impact Driver	10 Bulk	431051
C51P380E	⊕3x80E for Manual Impact Driver	10 Bulk	431052
C51MIXP4	4PC. Set for Manual Impact Driver	10 Bulk	431801

Manual Impact Driver 1/4" Hex Drive Set

- Thin handle. Can be used as normal screwdriver.
- Long shank bit. Ideal for hard-to-reach cramped spaces.
- Bit insertion part ⌀6.35mm



Model No. / Code	Set Contents	Package size (mm)
ID260002	Bits ⊕5, ⊕6, ⊕7, ⊕1, ⊕2, ⊕3×125	225x110x33
246016	Body length 32.5mm dia. 26mm	

INSERT BIT 1/4" Hex

Model No.	Set Content	Pack QTY	Code
C50P2125G	⊕2x125 for Manual Impact Driver	10 Bulk	431302
C50P3125G	⊕3x125 for Manual Impact Driver	10 Bulk	431303
C50MIXP6	6PC. Set for Manual Impact Driver	10 Bulk	431701

"L-KEY" Wrenches

VESSEL's Advanced Technology

The ball point tip-end is designed to be extracted smoothly even if it contacts with obstacles while tightening screws. It does not get caught or trapped in the hexagon screw head.

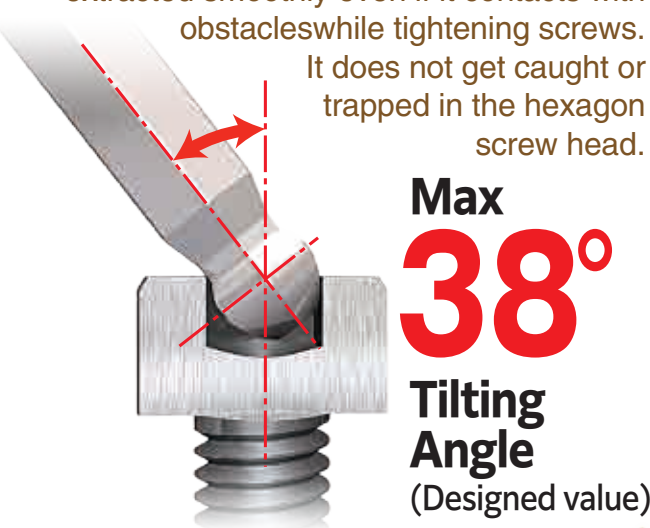

Max Tilting Angle 38°
(Designed value)

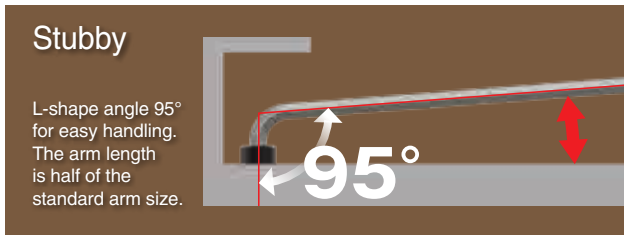
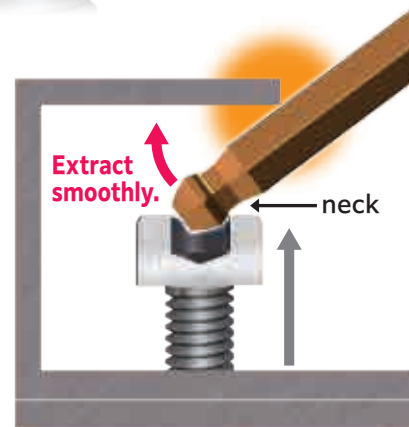

Ball Point Wrench Stubby (Short Type) 9-pc set

- Stubby ideal for cramped space
- L-shape angle 95° for easy handling



Model No. / Code	Set Contents
8209BPSU 143878	Ball Point Wrench Stubby (Short Type) ● 1.5, 2, 2.5, 3, 4, 5, 6, 8, 10 mm Carded Holder

Ball Point Wrench Stubby 9-pc set

- Stubby ideal for cramped space
- L-shape angle 95° for easy handling



Model No. / Code	Set Contents
8209BPU 143879	Ball Point Wrench Stubby ● 1.5, 2, 2.5, 3, 4, 5, 6, 8, 10 mm Carded Holder

Ball Point Wrench Stubby (Long Type) 9-pc set

- Stubby ideal for cramped space
- L-shape angle 95° for easy handling



Model No. / Code	Set Contents
8209BPLU 143880	Ball Point Wrench Stubby (Long Type) ● 1.5, 2, 2.5, 3, 4, 5, 6, 8, 10 mm Carded Holder

Ball Point Wrench 9-pc set

Model No. / Code	Set Contents
8309BPU 143881	Ball Point Wrench ● 1.5, 2, 2.5, 3, 4, 5, 6, 8, 10 mm Carded Holder

Ball Point Wrench (Long Type) 9-pc set

Model No. / Code	Set Contents
8309BPLU 143882	Ball Point Wrench (Long Type) ● 1.5, 2, 2.5, 3, 4, 5, 6, 8, 10 mm Carded Holder

Extra Long Ball point can reach deep spaces. Also, it is possible to apply force on the arm end.



Ball Point Wrench (Extra Long Type) 9-pc set

Model No. / Code	Set Contents
8309BPXLU 143883	Ball Point Wrench (Extra Long Type) ● 1.5, 2, 2.5, 3, 4, 5, 6, 8, 10 mm Carded Holder

Ball Point Wrench (Long Type) (Inch) 9-pc set

Model No. / Code	Set Contents
8309BPLINU 143884	Ball Point Wrench (Long Type) (Inch) ● 1/16, 5/64, 3/32, 1/8, 5/32, 3/16, 1/4, 5/16, 3/8 inch Carded Holder

Quick Tightening at tilted angle

Ball-shaped TORX wrench can tighten screws quickly even at a tilted angle. It is ideal for a work in a cramped space such as automotive maintenance.



Max Tilting Angle 25°
(Designed value)

Tamper-proof TORX® system

Tamper-proof TORX screw has a protrusion in the center of the screw recess that cannot be tightened or loosened with a standard TORX screwdriver.

*Not applicable for non-standard TORX screws



TORX®

Tip-end processing based on TORX standards. Corresponds to various screws.

Ball End TORX Wrench 9-pc set

Model No. / Code	Set Contents
8509BTXU 143885	Ball End TORX Wrench ● T8, T9, T10, T15, T20, T25, T27, T30, T40 mm Carded Holder

Tamper-proof TORX Wrench 9-pc set

Model No. / Code	Set Contents
8509TXHU 143886	Tamper-proof TORX Wrench ● T8H, T9H, T10H, T15H, T20H, T25H, T27H, T30H, T40H mm Carded Holder

Resistant to twist and breaking
Extra Superalloy

Made in Japan

VESSEL's Unique Steel Material

- Wear resistant material hardness.
- Rust resistant.
- Fully hardened.
- Magnetized.



Special alloy material also used in VESSEL's bits for impact screwdrivers. Special Heat treatment revealing superior material characteristics.

MEGADORA SCREWDRIVER

BALL GRIP SCREWDRIVER

SUPER CUSHION SCREWDRIVER

WOOD COMPO SERIES

FOR ELECTRONICS TOOLS/ USEFUL TOOLS

DRIVER SET SERIES

OTHER HAND TOOLS

L-WRENCH

IMPACT BALL

NECK-TORSION

DRYWALLER/ QB

INSERT BITS

POWER BITS

POWER BITS/ MAG CATCHER

DOUBLE-ENDED POWER BITS

NUT SETTERS

Bit Holder

PRECISION BITS

220USB SERIES
MEGADORA SCREWDRIVER
BALL GRIP SCREWDRIVER
SUPER CUSHION SCREWDRIVER
WOOD COMPO SERIES
FOR ELECTRONICS TOOLS/ USEFUL TOOLS
DRIVER SET SERIES
OTHER HAND TOOLS
L-WRENCH
IMPACT BALL
NECK-TORSION
DRYWALLER/ QB
INSERT BITS
POWER BITS
POWER BITS/ MAG CATCHER
DOUBLE-ENDED POWER BITS
NUT SETTERS
Bit Holder
PRECISION BITS



DRIVER BIT

WITHSTANDING HIGH IMPACT!

IMPACT BALL™ Screwdriver Bit



High Durability TOUGH 30X by shock absorption at Ball Torsion part

VoHA
Highest Hardness HRC 62
Using New Alloy Steel "VoHA" Highest Hardness 62 HRC

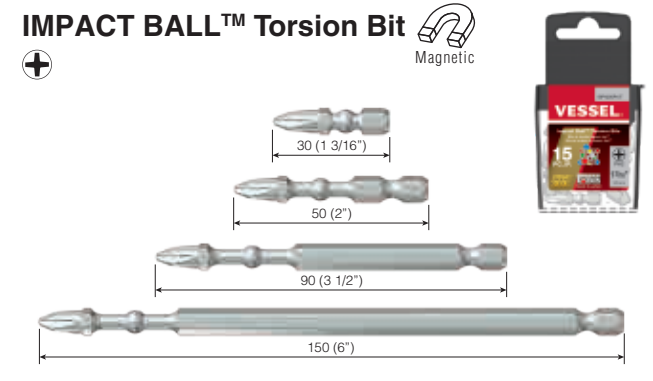

Model No.		mm	inch	Pack QTY		Code
IBPH130P2	⊕ PH1	30	1 3/16"	2	Carded	426030
IBPH130P25K	PH1	30	1 3/16"	25	Bulk	426065
IBPH230P2	PH2	30	1 3/16"	2	Carded	426031
IBPH230P5	PH2	30	1 3/16"	5	Carded	426033
IBPH230P25K	PH2	30	1 3/16"	25	Bulk	426066
IBPH230P15T	PH2	30	1 3/16"	15	TicTac	426102
IBPH330P2	PH3	30	1 3/16"	2	Carded	426032
IBPH330P25K	PH3	30	1 3/16"	25	Bulk	426067
IBPH150P25K	PH1	50	2"	25	Bulk	426083
IBPH250P25K	PH2	50	2"	25	Bulk	426084
IBPH250P15T	PH2	50	2"	15	TicTac	426593
IBPH350P25K	PH3	50	2"	25	Bulk	426085
IBPH290P10K	PH2	90	3 1/2"	10	Bulk	426086
IBPH2150P10K	PH2	150	6"	10	Bulk	426087

2 way use of Insert and Power!
Impact Ball™ 30mm (1 3/16") is applicable to Power Tools directly and also to Bit Holder.

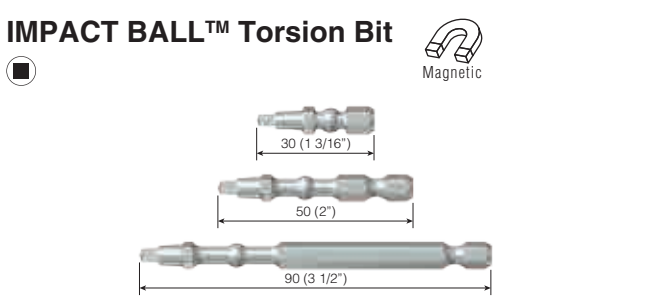

Model No.		mm	inch	Pack QTY		Code
IBSQ130P2	⊖ SQ1	30	1 3/16"	2	Carded	426037
IBSQ130P25K	SQ1	30	1 3/16"	25	Bulk	426071
IBSQ230P2	SQ2	30	1 3/16"	2	Carded	426038
IBSQ230P25K	SQ2	30	1 3/16"	25	Bulk	426072
IBSQ330P2	SQ3	30	1 3/16"	2	Carded	426039
IBSQ330P25K	SQ3	30	1 3/16"	25	Bulk	426073
IBSQ250P25K	SQ2	50	2"	25	Bulk	426088
IBSQ290P10K	SQ2	90	3 1/2"	10	Bulk	426089

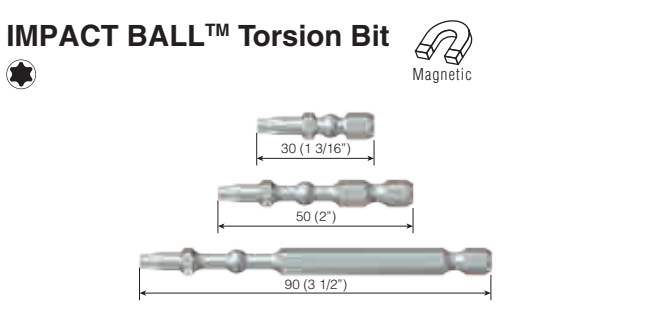

Model No.		mm	inch	Pack QTY		Code
IBTX1030P25K	⊖ T10	30	1 3/16"	25	Bulk	426090
IBTX1530P2	T15	30	1 3/16"	2	Carded	426034
IBTX1530P25K	T15	30	1 3/16"	25	Bulk	426068
IBTX2030P2	T20	30	1 3/16"	2	Carded	426035
IBTX2030P25K	T20	30	1 3/16"	25	Bulk	426069
IBTX2530P2	T25	30	1 3/16"	2	Carded	426036
IBTX2530P25K	T25	30	1 3/16"	25	Bulk	426070
IBTX3030P25K	T30	30	1 3/16"	25	Bulk	426091
IBTX1050P25K	T10	50	2"	25	Bulk	426092
IBTX1550P25K	T15	50	2"	25	Bulk	426093
IBTX2050P25K	T20	50	2"	25	Bulk	426094
IBTX2550P25K	T25	50	2"	25	Bulk	426095
IBTX3050P25K	T30	50	2"	25	Bulk	426096
IBTX2090P10K	T20	90	3 1/2"	10	Bulk	426097
IBTX2590P10K	T25	90	3 1/2"	10	Bulk	426098

220USB SERIES
MEGADORA SCREWDRIVER
BALL GRIP SCREWDRIVER
SUPER CUSHION SCREWDRIVER
WOOD COMPO SERIES
FOR ELECTRONICS TOOLS/ USEFUL TOOLS
DRIVER SET SERIES
OTHER HAND TOOLS
L-WRENCH
IMPACT BALL
NECK-TORSION
DRYWALLER/ QB
INSERT BITS
POWER BITS
POWER BITS/ MAG CATCHER
DOUBLE-ENDED POWER BITS
NUT SETTERS
Bit Holder
PRECISION BITS

IMPACT BALL™ Screwdriver Bit

Mag Charge!

Easy Magnetizing and Demagnetizing by friction.

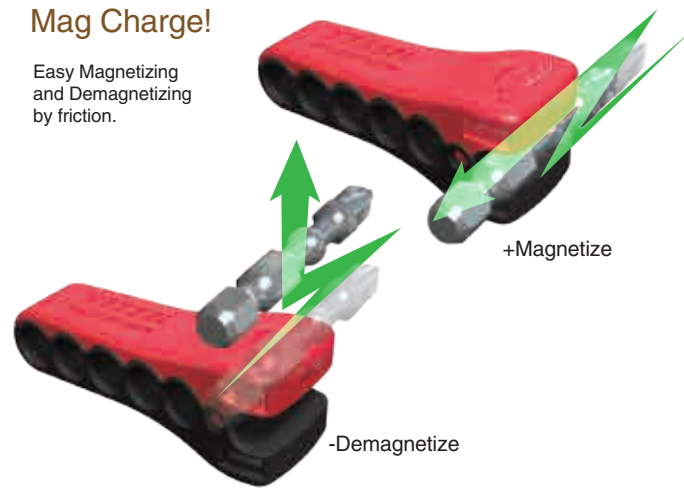

IMPACT BALL™ Torsion Bit with Mag Charge Holder

Model No. / Code

IBMG50PH2K5	⊕ (5)PH2	50	2"	Holder
426077				

IMPACT BALL™ Torsion Bit with Mag Charge Holder

Model No. / Code

IBMG50K001	⊕ (1)PH1, (3)PH2, (1)PH3	50	2"	Holder
426078				

IMPACT BALL™ Torsion Bit with Mag Charge Holder

Model No. / Code

IBMG50K002	⊕ (1)T10, (1)T15, (1)T20, (1)T25, (1)T30	50	2"	Holder
426079				

IMPACT BALL™ Torsion Bit with Mag Charge Holder

Model No. / Code

IBMG50K003	⊕ (2)PH2, (1)SQ2, (1)T20, (1)T25	50	2"	Holder
426080				

IMPACT BALL™ Torsion Bit with Mag Charge Holder

Model No. / Code

IBMG30K002	⊕ (1)T10, (1)T15, (1)T20, (1)T25, (1)T30	30	1 3/16"	Holder
426076				

IMPACT BALL™ Torsion Bit with Mag Charge Holder

Model No. / Code

IBMG90PH2K5	⊕ (5)PH2	90	3 1/2"	Holder
426081				

IMPACT BALL™ Torsion Bit with Mag Charge Holder

Model No. / Code

IBMG90K001	⊕ (1)PH1, (1)PH2, (1)PH3, (1)SL4, (1)SL6	90	3 1/2"	Carded
426121				

IMPACT BALL™ Torsion Bit with Mag Charge Holder

Model No. / Code

IBMG90K002	⊕ (1)PH2, (1)SL6, (1)SQ2, (1)T20, T25	90	3 1/2"	Carded
426122				

IMPACT BALL™ Torsion Bit with Mag Charge Holder

Model No. / Code

IBMG90K003	⊕ (1)PH2, PH3, (1)SQ1, SQ2, SQ3	90	3 1/2"	Carded
426123				

IMPACT BALL™ Torsion Bit with Mag Charge Holder

Model No. / Code

IBMG150PH2K5	⊕ (5)PH2	150	6"	Holder
426082				

IMPACT BALL™ Torsion Bit Holder

• Holding bits with a C-ring and a strong magnetic force



Model No.	mm	inch	Pack QTY		Code
IBHBM67P1	67	2 5/8"	1	Hanger	426111
IBHBM67P10K	67	2 5/8"	10	Bulk	426099
IBHBM150P1	150	6"	1	Hanger	426112
IBHBM150P10K	150	6"	10	Bulk	426100
IBHBM300P1	300	12"	1	Hanger	426113
IBHBM300P10K	300	12"	10	Bulk	426101

IMPACT BALL™ Torsion Bit 10+1 PC. Set in POP-UP CASE



Model No. / Code	Set Contents	mm	inch
IB11P02U	⊕ (1)PH1, (1)PH2, (1)PH3		
426114	⊖ (1)SL6, (1)SQ2, (1)T10, (1)T15, (1)T20, (1)T25, (1)T30	30	1 3/16"
	Magnet Bit Holder 60mm		

IMPACT BALL™ Torsion Bit 30+1 PC. Set in SLIDE CASE



Model No. / Code	Set Contents	mm	inch
IB31P02U	⊕ (1)PH1, (1)PH2, (1)PH3		
426115	⊕ (1)PZ1, (1)PZ2, (1)PZ3, (1)SL4, (1)SL6, (1)SL8, (1)SQ1, (1)SQ2, (1)SQ3, (1)T10, (1)T15, (1)T20, (1)T25, (1)T27, (1)T30, (1)T40, (1)H3, (1)H4, (1)H5, (1)H6, (1)H3/32, (1)H7/64, (1)H1/8, (1)H9/64, (1)H3/16, (1)H7/32, (1)H1/4"	30	1 3/16"
	Magnet Bit Holder 50mm		

NECK TORSION™ Screwdriver Bit

MEGADORA SCREWDRIVER

BALL GRIP SCREWDRIVER

SUPER CUSHION SCREWDRIVER

WOOD COMPO SERIES

FOR ELECTRONICS TOOLS/ USEFUL TOOLS

DRIVER SET SERIES

OTHER HAND TOOLS

L-WRENCH

IMPACT BALL

The reduced shank makes screw head visible. It's optimum to the fastening application in a narrow space.

Shock Absorption

TORSION ZONE

10x TOUGH™

VoHA
Highest Hardness HRC62

Using New Alloy Steel "VoHA" Highest Hardness 62 HRC

NECK TORSION™ Insert Bit 

Model No.		mm	inch	Pack QTY		Code
NCTX10254P25K	T10	25.4	1"	25	Bulk	426045
NCTX15254P3	T15	25.4	1"	3	Carded	426005
NCTX15254P25K	T15	25.4	1"	25	Bulk	426046
NCTX20254P3	T20	25.4	1"	3	Carded	426006
NCTX20254P25K	T20	25.4	1"	25	Bulk	426047
NCTX25254P3	T25	25.4	1"	3	Carded	426007
NCTX25254P25K	T25	25.4	1"	25	Bulk	426048
NCTX30254P25K	T30	25.4	1"	25	Bulk	426049

NECK TORSION™ Power Bit 

Model No.		mm	inch	Pack QTY		Code
NTPH150P2	PH1	50	2"	2	Carded	426017
NTPH150P25K	PH1	50	2"	25	Bulk	426053
NTPH250P2	PH2	50	2"	2	Carded	426018
NTPH250P5	PH2	50	2"	5	Carded	426022
NTPH250P25K	PH2	50	2"	25	Bulk	426054
NTPH350P2	PH3	50	2"	2	Carded	426021
NTPH350P25K	PH3	50	2"	25	Bulk	426055
NTPH275P2	PH2	75	3"	2	Carded	426019
NTPH275P10K	PH2	75	3"	10	Bulk	426062
NTPH2150P1	PH2	150	6"	1	Carded	426020
NTPH2150P10K	PH2	150	6"	10	Bulk	426063

NECK-TORSION™ Insert Bit 

Model No.		mm	inch	Pack QTY		Code
NTPH1254P3	PH1	25.4	1"	3	Carded	426001
NTPH1254P25K	PH1	25.4	1"	25	Bulk	426042
NTPH2254P3	PH2	25.4	1"	3	Carded	426002
NTPH2254P5	PH2	25.4	1"	5	Carded	426004
NTPH2254P25K	PH2	25.4	1"	25	Bulk	426043
NTPH2254P25T	PH2	25.4	1"	25	TicTac	426041
NTPH3254P3	PH3	25.4	1"	3	Carded	426003
NTPH3254P25K	PH3	25.4	1"	25	Bulk	426044

NECK TORSION™ Power Bit 

Model No.		mm	inch	Pack QTY		Code
NTSQ150P2	SQ1	50	2"	2	Carded	426026
NTSQ150P25K	SQ1	50	2"	25	Bulk	426059
NTSQ250P2	SQ2	50	2"	2	Carded	426027
NTSQ250P25K	SQ2	50	2"	25	Bulk	426060
NTSQ350P2	SQ3	50	2"	2	Carded	426028
NTSQ350P25K	SQ3	50	2"	25	Bulk	426061

NECK TORSION™ Insert Bit 

Model No.		mm	inch	Pack QTY		Code
NTSQ1254P3	SQ1	25.4	1"	3	Carded	426008
NTSQ1254P25K	SQ1	25.4	1"	25	Bulk	426050
NTSQ2254P3	SQ2	25.4	1"	3	Carded	426009
NTSQ2254P25K	SQ2	25.4	1"	25	Bulk	426051
NTSQ3254P3	SQ3	25.4	1"	3	Carded	426010
NTSQ3254P25K	SQ3	25.4	1"	25	Bulk	426052

NECK TORSION™ Power Bit 

Model No.		mm	inch	Pack QTY		Code
NCTX1550P2	T15	50	2"	2	Carded	426023
NCTX1550P25K	T15	50	2"	25	Bulk	426056
NCTX2050P2	T20	50	2"	2	Carded	426024
NCTX2050P25K	T20	50	2"	25	Bulk	426057
NCTX2550P2	T25	50	2"	2	Carded	426025
NCTX2550P25K	T25	50	2"	25	Bulk	426058

Double-Ended Bit is Our Invention.

2 in 1, Even when one side fails, the other side is drivable.

20x TOUGH™

NECK TORSION™ Double-Ended Power Bit 

Model No.		mm	inch	Pack QTY		Code
DEPH1PH150P2	PH1	50	2"	2	Carded	426011
DEPH2PH250P2	PH2	50	2"	2	Carded	426012
DEPH3PH350P2	PH3	50	2"	2	Carded	426013
DEPH2PH250P5	PH2	50	2"	5	Carded	426016

NECK TORSION™ Double-Ended Power Bit 

Model No.		mm	inch	Pack QTY		Code
DEPH2SQ250P2	PH2/SQ2	50	2"	2	Carded	426015

NECK TORSION™ Double-Ended Power Bit 

Model No.		mm	inch	Pack QTY		Code
DEPH2TX2550P2	PH2/T25	50	2"	2	Carded	426014

Stable fastening in a hollow place

Suitable in a hollow application with a long reach. Stable fastening with supportive plastic spring.

20x TOUGH™

RIB REINFORCED NECK TORSION™ Power Bit 

Model No.		mm	inch	Pack QTY		Code
RTPH2150P1	PH2	150	6"	1	Carded	426040
RTPH2150P10K	PH2	150	6"	10	Bulk	426064

NEW TicTac case

The package that is easy to take out bits

NECK TORSION™ Power Bits with MAG ENHANCER™ 

Model No.		mm	inch	Pack QTY		Code
MGEPH250P10T	PH2	50	2"	10	TicTac	426105

NECK TORSION™ Power Bits with MAG ENHANCER™ 

Model No.		mm	inch	Pack QTY		Code
MGETX1550P10T	T15	50	2"	10	TicTac	426106
MGETX2050P10T	T20	50	2"	10	TicTac	426107
MGETX2550P10T	T25	50	2"	10	TicTac	426108
MGETX3050P10T	T30	50	2"	10	TicTac	426109
MGETX4050P10T	T40	50	2"	10	TicTac	126110

Catch a screw by strong magnetic force

Magnetized bits get weakened by heat and vibration from work. Attaching Mag Enhancer maintains the magnetic force. Its holding power has 15 times more magnetic force.

Magnetic Force X15

1/4 6.35mm 1/4 6.35mm *Applicable to smaller diameter than 1/4 inch

MAG ENHANCER™ 

Model No.		mm	inch	Pack QTY		Code
MGEP2		21	0.83"	2	Blister	426103
MGEP25DSP		21	0.83"	25	TRAY	426104

Drywaller™ Screwdriver BIT/ Ball Grip™ Carrying Bit Holder

MEGADORA SCREWDRIVER

BALL GRIP SCREWDRIVER

REDUCED TIP

Reduced diameter for drywall screw

VoHA Highest Hardness HRC 62

Using New Alloy Steel "VoHA" Highest Hardness 62 HRC

Insert the bit, and it can be securely held.

One hand / One push removal design.

Can tighten a screw. (Applicable screw: M4 size or smaller)

Ball Grip™ Carrying Bit Holder

Unit: mm

QB-22RU QB-22YU QB-22GU QB-22VU QB-22KU

Model No.	Contents	Inner Ctn.	Code
QB22RU	Red x 1	1PC/CARDED	486937
QB22GU	Green x 1	1PC/CARDED	486939
QB22VU	Violet x 1	1PC/CARDED	486940
QB22YU	Yellow x 1	1PC/CARDED	486938
QB22KU	Black x 1	1PC/CARDED	487043

Good visibility at the bit tip and superior wear resistance

DRYWALLER™ Insert Bit

Magnetic

4.5 (3/16") 25.4 (1")

Model No.	mm	inch	Pack QTY	Code
DWPH2254P3	PH2 25.4	1"	3 Carded	426118
DWPH2254P25K	PH2 25.4	1"	25 Bulk	426116
DWPH2254P20T	PH2 25.4	1"	20 TicTac	426119

VESSEL Counter Display

IMPACT BALL™ Torsion Bits with Mag Charge Holder Counter Display

No.	Model No.	Description
1	IBMG30PH2K5	PH2 x 30 x 5PC. (MG Holder)
2	IBMG30K001	PH1, PH2, PH3, SQ2, SQ3 x 5PC. (MG Holder)
3	IBMG30K002	T10, T15, T20, T25, T30 x 30 x 5PC. (MG Holder)
4	IBMG50PH2K5	PH2 x 50 x 5PC. (MG Holder)
5	IBMG50K001	PH1, PH2, PH2, PH2, PH3 x 50 x 5PC. (MG Holder)
6	IBMG50K002	T10, T15, T20, T25, T30x 50 x 5PC. (MG Holder)
7	IBMG90PH2K5	PH2 x 90 x 5PC. (MG Holder)
8	IBMG150PH2K5	PH2X150 x 5PC. (MG Holder)
9	IBHBM67P10K	Torsion Bit Holder H1/4" x 67 x 10PC. (Bulk)
10	IBHBM150P10K	Torsion Bit Holder H1/4" x 150 x 10PC. (Bulk)
11	IBHBM300P10K	Torsion Bit Holder H1/4" x 300 x 10PC. (Bulk)



Displayer Dimensions: W11.8"(30cm) x D11"(27.8cm) x H18.3"(46.6cm)

IMPACT BALL™ Torsion Bits with Mag Charge Holder Counter Display

Displayer Dimensions: W9"(23cm) x D10.8"(27.5cm) x H7.9"(20cm)

No.	Model No.	Description
1	IBPH230P15T	PH2 x 30 x 15PC.
2	IBPH250P15T-DSP	IBPH250P15T x 15Pack

NECK TORSION™ Insert Bits Tic Tac Case Counter Display

Displayer Dimensions: W9"(23cm) x D10.8"(27.5cm) x H7.9"(20cm)

No.	Model No.	Description
1	NTPH2254P25T	PH2 x 25.4 x 25PC.

DRYWALLER™ Insert Bits Tic Tac Case Counter Display

Display Dimensions: W9"(23cm) x D10.8"(27.5cm) x H7.9"(20cm)

No.	Model No.	Description
1	DWPH2254P20T-DSP	DWPH2254P20T x 15Pack

NECK TORSION™ Power Bits with Mag ENHANCER™ Tic Tac Case Counter Display

Displayer Dimensions: W9"(23cm) x D10.8"(27.5cm) x H7.9"(20cm)

No.	Model No.	Description
1	MGEPH250P10T/D	MGEPH250P10T x 15Pack
2	MGETX/SET2	MGETX1550P10T x 5Pack
		MGETX2050P10T x 5Pack
		MGETX2550P10T x 5Pack

No.	Model No.	Description
3	MGETX/SET4	MGETX2550P10T x 5Pack
		MGETX3050P10T x 5Pack
		MGETX4050P10T x 5Pack
		MGETX4050P10T x 5Pack

MAG ENHANCER™ 25PC. Counter Display

No.	Model No.	Description
1	MGEP25-DSP	Mag Enhancer x 25PC.

MAG ENHANCER™

*Applicable to smaller diameter than 1/4 inch

Model No.	Overall Length	Inner Ctn.	Code
MGEP2	21	2PC/CARDED	426103
MGEP25-DSP	21	25PC/TRAY	426104

A Long Lasting Technology

Breakage of a screwdriver bit not only reduces work efficiency but also adversely affects the quality of an assembled product. Improving durability of a screwdriver bit is a critical issue for assembly lines.

Pursuit of Durability

Alloy Steel including substances such as C, Si, Ni, Cr, Mo, and V, which gives a high hardness and toughness, is heat treated by our own furnace and technology in order to make our screwdriver bits outstanding quality and durability.

“VoHA” steel is compounded a special alloy element used for materials in aerospace industry. Combination with NECK TORSION™ technology, it is possible to dramatically reduce the breakage of the bit tip.

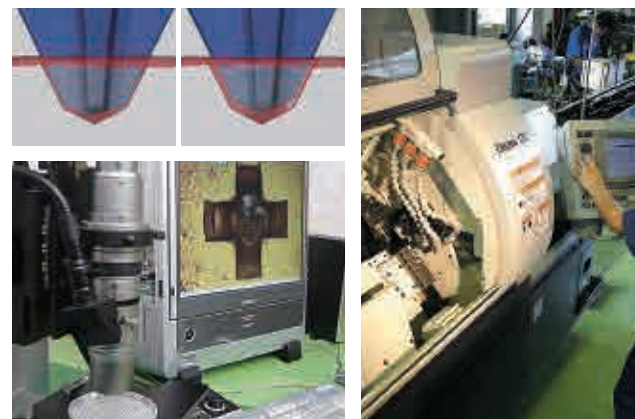

Tip Toughness Test

Torsion force is increased until failure and to show the highest torque value.

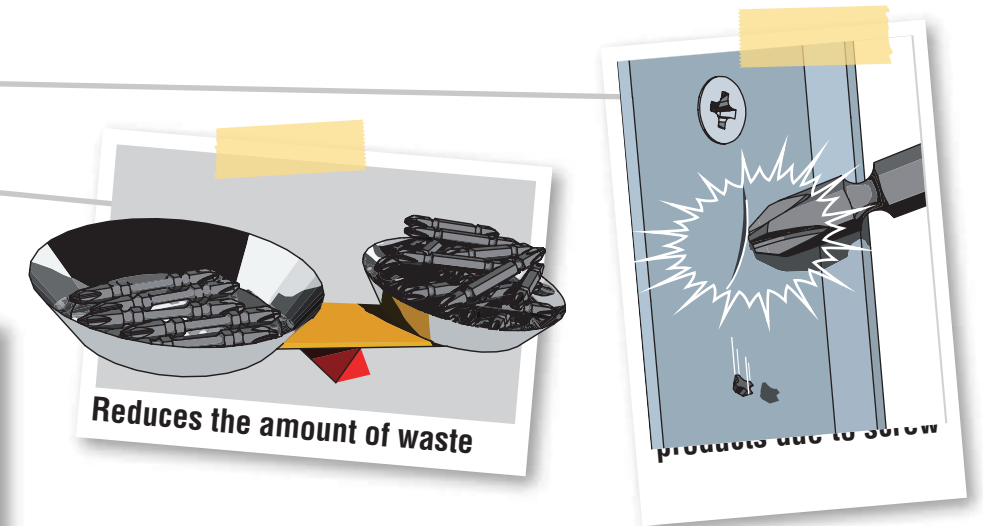
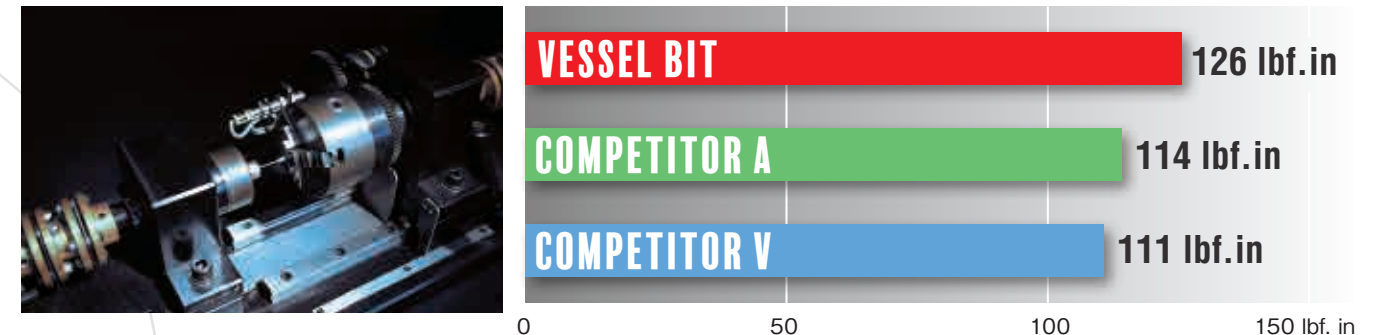

Precision Fitting

Screwdriver bits are produced with less variation by improvement of machining accuracy with superior machines and thorough quality control. The tip profile is thoroughly analyzed for fitting well with screws using a 3D digitizer.

Ideal fitting not only prevents stripping a screw head but also improves the durability of screwdriver bit.



Selecting Phillips tip according to hardness classification

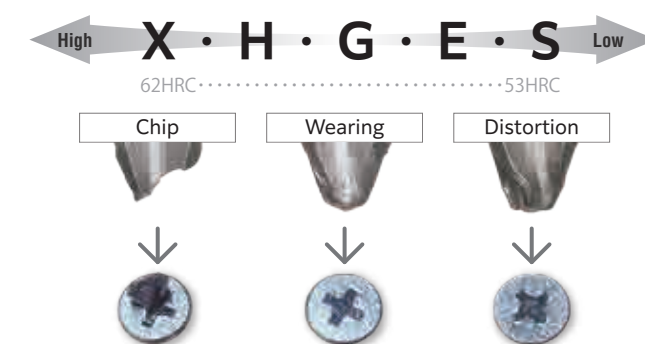

Easy to fracture when a bit is higher than optimum hardness
Easy to wear-out or distort when a bit is lower than optimum hardness

Mag Applied Technology

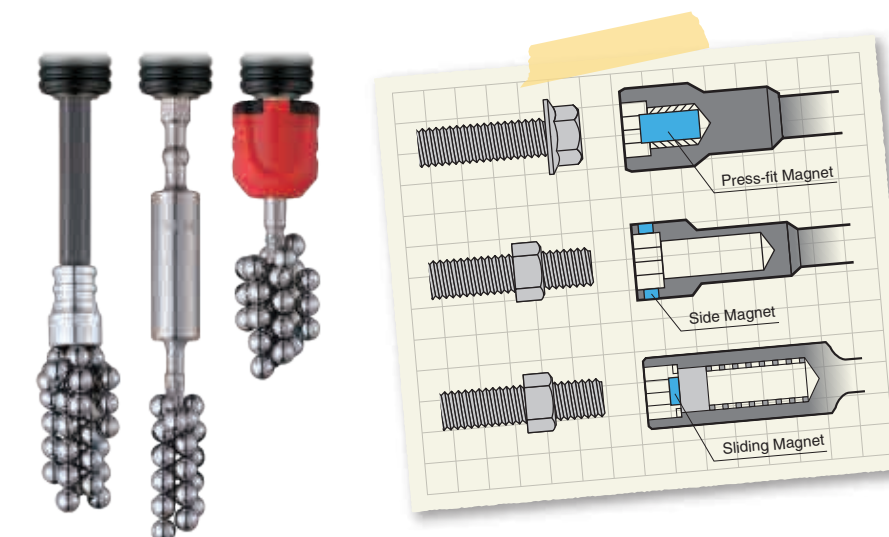

Hold a screw with strong magnetic force. Magnet applied technology is a significantly effective tools for the prevention of screw fall-off during work. A wide variety of products are offered depending upon each work application.

Insert Bits



NECK TORSION

It absorbs and reduces vibration occurred during screwing into tree knots, tapping, and such application. It suppresses bounce of a bit itself and can be expected improvement of work efficiency and long life of a bit.

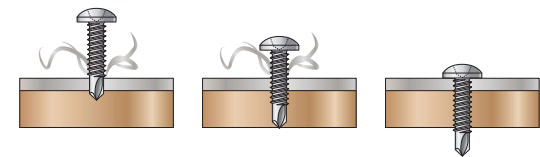

Drive : 1/4 DIN 3126-C6.3, ISO 1173  H 6.35mm

1/4" Hex NECK TORSION™ Insert Bit

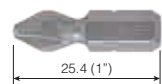

Model No.	Tip Size	Overall Length	Hardness	Inner Ctn.	Code
NTPH1254P3	PH1	25.4	X	3PC/Carded	426001
NTPH2254P3	PH2	25.4	X	3PC/Carded	426002
NTPH3254P3	PH3	25.4	X	3PC/Carded	426003
NTPH2254P5	PH2	25.4	X	5PC/Carded	426004
NTPH2254P25T	PH2	25.4	X	25PC/TicTac	426041
NTPH1254P25K	PH1	25.4	X	25	426042
NTPH2254P25K	PH2	25.4	X	25	426043
NTPH3254P25K	PH3	25.4	X	25	426044

1/4" Hex NECK TORSION™ Insert Bit

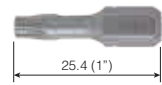

Model No.	Tip Size	Overall Length	Hardness	Inner Ctn.	Code
NTTX15254P3	T15	25.4	X	3PC/Carded	426005
NTTX20254P3	T20	25.4	X	3PC/Carded	426006
NTTX25254P3	T25	25.4	X	3PC/Carded	426007
NTTX10254P25K	T10	25.4	X	25	426045
NTTX15254P25K	T15	25.4	X	25	426046
NTTX20254P25K	T20	25.4	X	25	426047
NTTX25254P25K	T25	25.4	X	25	426048
NTTX30254P25K	T30	25.4	X	25	426049

1/4" Hex NECK TORSION™ Insert Bit



Model No.	Tip Size	Overall Length	Hardness	Inner Ctn.	Code
NTSQ1254P3	SQ1	25.4	X	3PC/Carded	426008
NTSQ2254P3	SQ2	25.4	X	3PC/Carded	426009
NTSQ3254P3	SQ3	25.4	X	3PC/Carded	426010
NTSQ1254P25K	SQ1	25.4	X	25	426050
NTSQ2254P25K	SQ2	25.4	X	25	426051
NTSQ3254P25K	SQ3	25.4	X	25	426052

1/4" Hex Insert Bit



Model No.	Tip Size	Overall Length	Hardness	Inner Ctn.	Code
B33P03254H	PH0	25.4	H	10	426124
B33P1254H	PH1	25.4	H	10	421231
B33P145254H	PH1	25.4	H	10	426120
B33P2254H	PH2	25.4	H	10	421241
B33P25254H	PH2	25.4	H	10	426125
B33P3254G	PH3	25.4	G	10	421242

1/4" Hex Insert Bit



Model No.	Tip Width/ Shank Diameter	Overall Length	Hardness	Inner Ctn.	Code
B33S4254G	4	25.4	G	10	421251
B33S6254G	6	25.4	G	10	421252

1/4" Hex Insert Bit



Model No.	Tip Size	Overall Length	Hardness	Inner Ctn.	Code
B33H2254H	H2	25.4	H	10	421260
B33H25254H	H2.5	25.4	H	10	421261
B33H3254H	H3	25.4	H	10	421262
B33H4333H	H4	33	H	10	421263
B33H5333H	H5	33	H	10	421264
B33H6333H	H6	33	H	10	421265

1/4" Hex Insert Bit

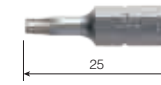

Model No.	Tip Size	Overall Length	Inner Ctn.	Code
B33T325H	T3	25	10	489154
B33T525H	T5	25	10	489155
B33T6254H	T6	25.4	10	635400
B33T725H	T7	25	10	489157
B33T8254H	T8	25.4	10	635401
B33T10254H	T10	25.4	10	635402
B33T15254H	T15	25.4	10	635403
B33T20254H	T20	25.4	10	635404
B33T25254H	T25	25.4	10	635405
B33T27254H	T27	25.4	10	635406
B33T30254H	T30	25.4	10	635407
B33T40254H	T40	25.4	10	635408

1/4" Hex Insert Bit



Model No.	Tip Size	Overall Length	Hardness	Inner Ctn.	Code
B33IP1525H	15IP	25	H	10	447204
B33IP2025H	20IP	25	H	10	447205
B33IP2525H	25IP	25	H	10	447206
B33IP3025H	30IP	25	H	10	447207
B33IP4025H	40IP	25	H	10	447208

Drive : 5/16 DIN 3126-C8, ISO 1173  H 8mm

5/16" Hex Insert Bit



Model No.	Tip Size	Overall Length	Inner Ctn.	Code
A5T3032H	T30	32	10	635427
A5T4032H	T40	32	10	635428
A5T4532H	T45	32	10	635429
A5T5032H	T50	32	10	635430

Drive : 1/4 DIN 3126-C6.3, ISO 1173  H 6.35mm

Magnet Screw Catcher

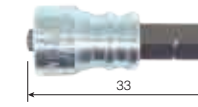

Model No.	Tip Size	Overall Length	Inner Ctn.	Code
B33MMBCP133H	PH1	33	10	447105
B33MMBCP233H	PH2	33	10	447106

Magnet Screw Catcher

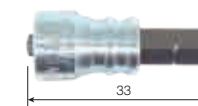

Model No.	Tip Size	Overall Length	Inner Ctn.	Code
B33MMBCPZ133H	PZ1	33	10	447107
B33MMBCPZ233H	PZ2	33	10	447108

Magnet Screw Catcher

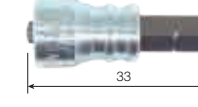

Model No.	Tip Size	Overall Length	Inner Ctn.	Code
B33MMBCT1033H	T10	33	10	447104
B33MMBCT1533H	T15	33	10	447102
B33MMBCT2033H	T20	33	10	447103
B33MMBCT2533H	T25	33	10	447110

Replacement Bits For MMBC Series



Model No.	Tip Size	Overall Length	Inner Ctn.	Code
B33MMBCT1033HRB	T10	33	10	447329
B33MMBCT1533HRB	T15	33	10	447330
B33MMBCT2033HRB	T20	33	10	447331
B33MMBCT2533HRB	T25	33	10	447332
B33MMBCP133HRB	PH1	33	10	447333
B33MMBCP233HRB	PH2	33	10	447334
B33MMBCPZ133HRB	PZ1	33	10	447335
B33MMBCPZ233HRB	PZ2	33	10	447336

Power Bits

Drive : 1/4 DIN 3126-E6.3, ISO 1173

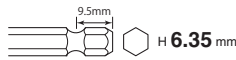

1/4" Hex NECK TORSION™ Power Bit

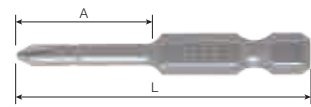

Model No.	Tip Size	Overall Length	Length (A)	Hardness	Inner Ctn.	Code
NTPH150P2	PH1	50	25	X	2PC/Carded	426017
NTPH250P2	PH2	50	25	X	2PC/Carded	426018
NTPH350P2	PH3	50	25	X	2PC/Carded	426021
NTPH250P5	PH2	50	25	X	5PC/Carded	426022
NTPH250P15T	PH2	50	25	X	15PC/TicTac	426029
NTPH150P25K	PH1	50	25	X	25	426053
NTPH250P25K	PH2	50	25	X	25	426054
NTPH350P25K	PH3	50	25	X	25	426055
NTPH275P2	PH2	75	25	X	2PC/Carded	426019
NTPH275P10K	PH2	75	25	X	10	426062
NTPH2150P1	PH2	150	100	X	1PC/Carded	426020
NTPH2150P10K	PH2	150	100	X	10	426063

1/4" Hex NECK TORSION™ Power Bit

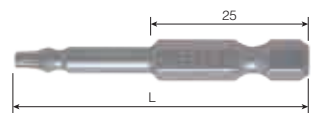

Model No.	Tip Size	Overall Length	Hardness	Inner Ctn.	Code
NTTX1550P2	T15	50	X	2PC/Carded	426023
NTTX2050P2	T20	50	X	2PC/Carded	426024
NTTX2550P2	T25	50	X	2PC/Carded	426025
NTTX1550P25K	T15	50	X	25	426056
NTTX2050P25K	T20	50	X	25	426057
NTTX2550P25K	T25	50	X	25	426058

1/4" Hex NECK TORSION™ Power Bit

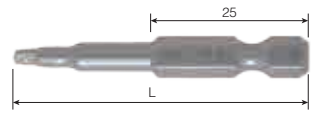

Model No.	Tip Size	Overall Length	Hardness	Inner Ctn.	Code
NTSQ150P2	SQ1	50	X	2PC/Carded	426026
NTSQ250P2	SQ2	50	X	2PC/Carded	426027
NTSQ350P2	SQ3	50	X	2PC/Carded	426028
NTSQ150P25K	SQ1	50	X	25	426059
NTSQ250P25K	SQ2	50	X	25	426060
NTSQ350P25K	SQ3	50	X	25	426061

1/4" Hex Power BIT



Model No.	Tip Size	Overall Length	Hardness	Body Diameter	Inner Ctn.	Code
B35P00122060H	PH00	60	H	1.2	10	446126
B35P0015849H	PH00	49	H	1.58	10	446423
B35P00240100H	PH00	100	H	2.0	10	446141
B35P031749H	PH0	49	H	3.17	10	487195
B35P0143060H	PH0	60	H	1.4	10	446145
B35P022060H	PH0	60	H	2.0	10	446153
B35P0230100H	PH0	100	H	2.0	10	446157
B35P150H	PH1	50	H	7	10	424032
B35P175H	PH1	75	H	7	10	424035
B35P145100H	PH1	100	H	4.5	10	424036
B35P14889H	PH1	89	H	4.8	10	487202
B35P248100H	PH2	100	H	4.8	10	446429
B35P26100H	PH2	100	H	6	10	489255
B35P26150H	PH2	150	H	6	10	489673
B35P26200H	PH2	200	H	6	10	446439
B35P263549H	PH2	49	H	6.4	10	487205
B35P263570H	PH2	70	H	6.35	10	487206
B35P263589H	PH2	89	H	6.35	10	487207
B35P2635152H	PH2	152	H	6.35	10	487208
B35P250X	PH2	50	X	7	10	424061
B35P250G	PH2	50	G	7	10	424040
B35P275X	PH2	75	X	7	10	424062
B35P275H	PH2	75	H	7	10	424047
B35P275G	PH2	75	G	7	10	424041
B35P275E	PH2	75	E	7	10	424042
B35P2775100H	PH2	100	H	7	10	424048
B35P2100G	PH2	100	G	7	10	424043
B35P2100E	PH2	100	E	7	10	424044
B35P2150H	PH2	150	H	7	10	424049
B35P2150G	PH2	150	G	7	10	424045
B35P2150E	PH2	150	E	7	10	424046
B35P245100H	PH2	100	H	4.5	10	424038
B35P349H	PH3	49	H	7.9	10	487210
B35P389H	PH3	89	H	7.9	10	487212
B35P375H	PH3	75	H	7	10	424050
B35P375E	PH3	75	E	7	10	424051
B35P3100H	PH3	100	H	7	10	424052
B35P3100E	PH3	100	E	7	10	424053
B35P3150G	PH3	150	G	7	10	424054

1/4" Hex Power BIT

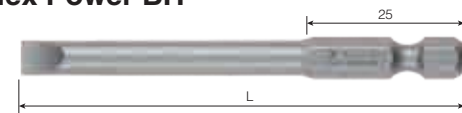

Model No.	Overall Length	Hardness	Tip Width/ Shank Diameter	Inner Ctn.	Code
B35S675E	75	E	6	10	424075
B35S6351049H	49	H	6.35	10	487245
B35S791249H	49	H	7.9	10	487255

1/4" Hex Power BIT

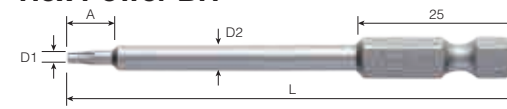

Model No.	Tip Size	Overall Length	Length (A)	Body Diameter(D1)	Body Diameter(D2)	Inner Ctn.	Code
B35T549H	T5	49	6.5	1.67	3.18	10	446486
B35T570H	T5	70	6.5	1.67	3.18	10	447355
B35T589H	T5	89	6.5	1.67	3.18	10	447356
B35T675H	T6	75	6.5	1.95	3.96	10	635300
B35T6100H	T6	100	6.5	1.95	3.96	10	635301
B35T6152H	T6	152	6.5	1.95	3.18	10	447317
B35T770H	T7	70	6.5	2.27	3.18	10	446499
B35T775H	T7	75	6.5	2.27	4	10	635303
B35T790H	T7	90	6.5	2.27	3.18	10	446509
B35T7152H	T7	152	6.5	2.27	3.18	10	446519
B35T849H	T8	49	7.0	2.6	3.18	10	446489
B35T870H	T8	70	7.0	2.6	3.18	10	446500
B35T875H	T8	75	7.0	2.6	4.5	10	635305
B35T890H	T8	90	7.0	2.6	3.18	10	446510
B35T8100H	T8	100	7.0	2.6	4.5	10	635306
B35T8152H	T8	152	7.0	2.6	3.18	10	446520
B35T970H	T9	70	7.0	2.78	3.18	10	446501
B35T990H	T9	90	7.0	2.78	3.18	10	446511
B35T9152H	T9	152	7.0	2.78	3.18	10	446521
B35T1049H	T10	49	7.5	3.02	3.96	10	446491
B35T1070H	T10	70	7.5	3.02	3.96	10	446502
B35T1075H	T10	75	7.5	3.02	4.5	10	635310
B35T10100H	T10	100	7.5	3.02	4.5	10	635311
B35T10152H	T10	152	7.5	3.02	3.96	10	446522
B35T1549H	T15	49	7.5	3.56	3.96	10	446492
B35T1570H	T15	70	7.5	3.56	3.96	10	446503
B35T1575H	T15	75	7.5	3.56	4.5	10	635315
B35T1590H	T15	90	7.5	3.56	3.96	10	446513
B35T15100H	T15	100	7.5	3.56	4.5	10	635316
B35T15152H	T15	152	7.5	3.56	3.96	10	446523
B35T2049H	T20	49	4.75	4.14	4.75	10	446493
B35T2070H	T20	70	4.75	4.14	4.75	10	446504
B35T2075H	T20	75	4.75	4.14	5	10	635320
B35T20100H	T20	100	4.75	4.14	5	10	635321
B35T20152H	T20	152	4.75	4.14	4.37	10	446524
B35T2570H	T25	70	8.0	4.7	5	10	446505
B35T2575H	T25	75	8.0	4.7	5	10	635325
B35T25100H	T25	100	8.0	4.7	5	10	635326
B35T25152H	T25	152	8.0	4.7	4.75	10	446525
B35T2775H	T27	75	8.0	5.26	5.5	10	635330
B35T27100H	T27	100	8.0	5.26	5.5	10	635331
B35T27152H	T27	152	8.0	5.26	6.4	10	446526
B35T3070H	T30	70	8.5	5.79	6.4	10	446507
B35T3075H	T30	75	8.5	5.79	6	10	635335
B35T3090H	T30	90	8.5	5.79	6.4	10	446517
B35T30100H	T30	100	8.5	5.79	6	10	635336
B35T30152H	T30	152	8.5	5.79	6.4	10	446527
B35T4049H	T40	49	-	-	7	10	446497
B35T4070H	T40	70	-	-	8	10	446508
B35T4075H	T40	75	-	-	8	10	635340
B35T4090H	T40	90	-	-	8	10	446518
B35T40100H	T40	100	-	-	7	10	635341

Model No.	Tip Size	Overall Length	Length (A)	Body Diameter(D1)	Body Diameter(D2)	Inner Ctn.	Code
B35T40152H	T40	152	-	-	8	10	446528
B35T4575H	T45	75	-	-	7.9	10	635345
B35T45100H	T45	100	-	-	7.9	10	635346

1/4" Hex Power BIT

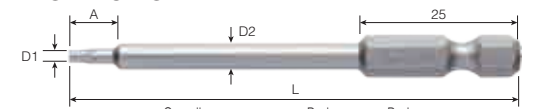

Model No.	Tip Size	Overall Length	Length (A)	Body Diameter(D1)	Body Diameter(D2)	Inner Ctn.	Code
B35T6H75H	T6H	75	6.5	1.95	3.96	10	635283
B35T6H100H	T6H	100	6.5	1.95	3.96	10	635284
B35T8H75H	T8H	75	7.0	2.60	4.5	10	635285
B35T8H100H	T8H	100	7.0	2.60	4.5	10	635286
B35T10H49H	T10H	49	7.5	3.02	3.96	10	446533
B35T10H70H	T10H	70	7.5	3.02	3.96	10	446544
B35T10H75H	T10H	75	7.5	3.02	4.5	10	635251
B35T10H100H	T10H	100	7.5	3.02	4.5	10	635252
B35T15H75H	T15H	75	7.5	3.56	4.5	10	635255
B35T15H100H	T15H	100	7.5	3.56	4.5	10	635256
B35T20H49H	T20H	49	7.5	4.14	4.37	10	446535
B35T20H70H	T20H	70	7.5	4.14	4.37	10	446546
B35T20H75H	T20H	75	7.5	4.14	5	10	635261
B35T20H100H	T20H	100	7.5	4.14	5	10	635262
B35T25H75H	T25H	75	8.0	4.70	5	10	635265
B35T25H100H	T25H	100	8.0	4.70	5	10	635266
B35T27H75H	T27H	75	8.0	5.26	5.5	10	635271
B35T27H100H	T27H	100	8.0	5.26	5.5	10	635272
B35T30H75H	T30H	75	8.5	5.79	6	10	635275
B35T30H100H	T30H	100	8.5	5.79	6	10	635276
B35T40H75H	T40H	75	-	-	7	10	635281
B35T40H100H	T40H	100	-	-	7	10	635282

1/4" Hex Power BIT



Power Bits/ Mag Catcher

Drive : 1/4 DIN 3126-E6.3, ISO 1173  H 6.35mm

1/4" Hex Power BIT

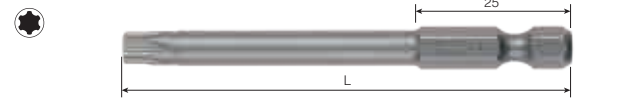

Model No.	Tip Size	Overall Length	Hardness	Body Diameter	Inner Ctn.	Code
B35IP6152H	6IP	152	H	1.64	10	447251
B35IP7152H	7IP	152	H	1.99	10	447252
B35IP8152H	8IP	152	H	2.31	10	447253
B35IP949H	9IP	49	H	2.5	10	447229
B35IP970H	9IP	70	H	2.5	10	447236
B35IP990H	9IP	90	H	2.5	10	447243
B35IP9152H	9IP	152	H	2.5	10	447226
B35IP1090H	10IP	90	H	2.74	10	447244
B35IP10152H	10IP	152	H	2.74	10	447254
B35IP1549H	15IP	49	H	3.27	10	447230
B35IP1570H	15IP	70	H	3.27	10	447237
B35IP1590H	15IP	90	H	3.27	10	447245
B35IP15152H	15IP	152	H	3.27	10	447255
B35IP2049H	20IP	49	H	3.86	10	447231
B35IP2070H	20IP	70	H	3.86	10	447238
B35IP2090H	20IP	90	H	3.86	10	447246
B35IP20152H	20IP	152	H	3.86	10	447256
B35IP2549H	25IP	49	H	4.43	10	447232
B35IP2570H	25IP	70	H	4.43	10	447239
B35IP2590H	25IP	90	H	4.43	10	447247
B35IP25152H	25IP	152	H	4.43	10	447257
B35IP3049H	30IP	49	H	5.52	10	447234
B35IP3070H	30IP	70	H	5.52	10	447241
B35IP3090H	30IP	90	H	5.52	10	447249
B35IP30152H	30IP	152	H	5.52	10	447259
B35IP4049H	40IP	49	H	6.65	10	447235
B35IP4070H	40IP	70	H	6.65	10	447242
B35IP4090H	40IP	90	H	6.65	10	447250
B35IP40152H	40IP	152	H	6.65	10	447260

1/4" Hex Power BIT



Model No.	Tip Size	Overall Length	Hardness	Inner Ctn.	Code
B35P123H	PH1	23	H	10	424131
B35P223H	PH2	23	H	10	424141
B35P240H	PH2	40	H	10	424143
B35P2100H	PH2	100	H	10	424147

1/4" Hex Power BIT



Model No.	Tip Size	Overall Length	Hardness	Body Diameter	Inner Ctn.	Code
B35PZ14850H	PZ1	50	4.8	H	10	424101
B35PZ26350H	PZ2	50	6.3	H	10	424102
B35PZ3850H	PZ3	50	8	H	10	424103

1/4" Hex Power BIT



Model No.	Tip Size	Overall Length	Hardness	Inner Ctn.	Code
B35TW140H	TW1	40	H	10	424201
B35TW240H	TW2	40	H	10	424202
B35TW340H	TW3	40	H	10	424203
B35TW440H	TW4	40	H	10	424204

1/4" Hex NECK TORSION™ Mag Catcher Power Bit



Model No.	Tip Size	Overall Length	Inner Ctn.	Code
B35MMBCT1049H	T10	49	10	447111
B35MMBCT1070H	T10	70	10	447112
B35MMBCT1549H	T15	49	10	447115
B35MMBCT1570H	T15	70	10	447116
B35MMBCT2049H	T20	49	10	447113
B35MMBCT2075H	T20	75	10	447101
B35MMBCT20150H	T20	150	10	447109
B35MMBCT2549H	T25	49	10	447117
B35MMBCT2570H	T25	70	10	447118

1/4" Hex NECK TORSION™ Mag Catcher Insert Bit Replacement Bit



Model No.	Tip Size	Overall Length	Inner Ctn.	Code
B35MMBCT1049HRB	T10	49	10	447337
B35MMBCT1070HRB	T10	70	10	447338
B35MMBCT1549HRB	T15	49	10	447361
B35MMBCT1570HRB	T15	70	10	447362
B35MMBCT2049HRB	T20	49	10	447339
B35MMBCT2075HRB	T20	75	10	447340
B35MMBCT20150HRB	T20	150	10	447341

1/4" Hex Power Bit Reduced Shaft



Model No.	Tip Size	Overall Length	Length (A(B))	Hardness	Body Diameter	Inner Ctn.	Code
MAB16P24565H	PH2	65	40	H	4.5	10	415301
MAB16P245100H	PH2	100	75	H	4.5	10	415302
MAB16P245150H	PH2	150	50(75)	H	4.5	10	415303

MAGNETIC SCREW CATCHER

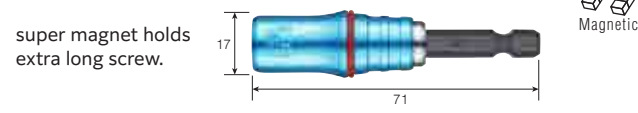

Model No.	Overall Length	Inner Ctn.	Code
MBCAF63571	71	1PC	486345

Double-Ended Power Bits

Drive : 1/4 DIN 3126-E6.3, ISO 1173  H 6.35mm

1/4" Hex Double-Ended Power BIT



Model No.	Tip Size	Overall Length	Hardness	Inner Ctn.	Code
B43P175H	PH1	75	H	10	425032
B43P250X	PH2	50	X	10	425036
B43P250H	PH2	50	H	10	425037
B43P250E	PH2	50	E	10	425038
B43P275X	PH2	75	X	10	425039
B43P275H	PH2	75	H	10	425040
B43P275G	PH2	75	G	10	425041
B43P275E	PH2	75	E	10	425042
B43P2100X	PH2	100	X	10	425046
B43P2100H	PH2	100	H	10	425047
B43P2100G	PH2	100	G	10	425043
B43P2100E	PH2	100	E	10	425044
B43P2150X	PH2	150	X	10	425048
B43P2150H	PH2	150	H	10	425049
B43P2150G	PH2	150	G	10	425045
B43P2200G	PH2	200	G	10	425050
B43P2300H	PH2	300	H	10	446373
B43P375H	PH3	75	H	10	425054
B43P375E	PH3	75	E	10	425055
B43P3100H	PH3	100	H	10	425057
B43P3100E	PH3	100	E	10	425058
B43P3150H	PH3	150	H	10	446375

1/4" Hex Double-Ended Power BIT



Model No.	Tip Size	Overall Length	Hardness	Inner Ctn.	Code
MB43P275H	PH2	75	H	10	446669
MB43P2100H	PH2	100	H	10	446672
MB43P2150H	PH2	150	H	10	446673

1/4" Hex Double-Ended Power BIT



Model No.	Tip Size	Overall Length	Hardness	Inner Ctn.	Code
B43PP275H	PH2	75	H	10	425171
B43PP2100H	PH2	100	H	10	425172

1/4" Hex Double-Ended Power BIT



Model No.	Tip Size	Overall Length	Hardness	Inner Ctn.	Code
B43HP275H	PH2	75	H	10	425151
B43HP2100H	PH2	100	H	10	425153
B43HP2150H	PH2	150	H	10	425155

1/4" Hex Double-Ended Power BIT



Model No.	Tip Size	Overall Length	Hardness	Inner Ctn.	Code
B43BP250S	PH2	50	S	10	425141
B43BP275S	PH2	75	S	10	425142
B43BP2100S	PH2	100	S	10	425143
B43BP2150S	PH2	150	S	10	425144

1/4" Hex Double-Ended Power BIT

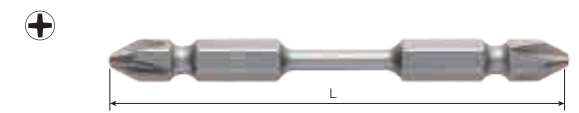

Model No.	Tip Size	Overall Length	Hardness	Body Diameter	Inner Ctn.	Code
BT43P275H	PH2	75	H	Torsion	10	425161
BT43P2100H	PH2	100	H	Torsion	10	425162

1/4" Hex Double-Ended Power BIT



Model No.	Tip Size	Overall Length	Hardness	Body Diameter	Inner Ctn.	Code
BT43PP275X	PH2	75	X	Torsion	10	425201
BT43PP2100X	PH2	100	X	Torsion	10	425202

Selecting best fit Phillips tip* for various screw types

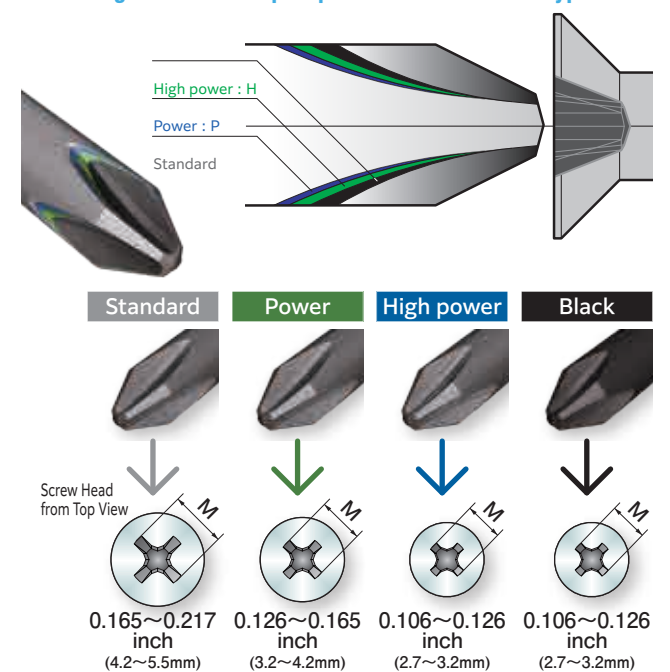

* M dimension : width across flats of screw recess from the top view
 * Phillips is a registered trademark of Phillips Screw Co.

* All dimensions are in metric. Please contact us if you'd like to know it in imperial.

Nut Setters

220USB SERIES

MEGADORA SCREWDRIVER

BALL GRIP SCREWDRIVER

SUPER CUSHION SCREWDRIVER

WOOD COMPO SERIES

FOR ELECTRONICS TOOLS/ USEFUL TOOLS

DRIVER SET SERIES

OTHER HAND TOOLS

L-WRENCH

IMPACT BALL

NECK-TORSION

DRYWALLER/ QB

INSERT BITS

POWER BITS

POWER BITS/ MAG CATCHER

DOUBLE-ENDED POWER BITS

NUT SETTERS

Bit Holder

PRECISION BITS



Drive : 1/4 DIN 3126-C6.3, ISO 1173  H 6.35 mm

Nutsetter 1/4" Hex Nutsetter Metric

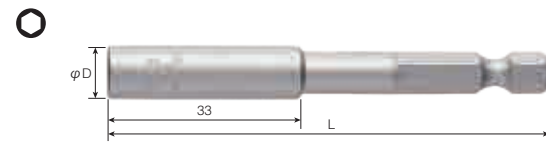

Model No.	Socket Size	Overall Length	Socket Nose Diameter φ	Inner Ctn.	Code
B45AF450	A/F4	50	8	10	489301
B45AF475	A/F4	75	8	10	489314
B45AF4100	A/F4	100	8	10	489327
B45AF4550	AF/4.5	50	8	10	489302
B45AF550	AF/5	50	8	10	489303
B45AF575	AF/5	75	8	10	489316
B45AF5100	AF/5	100	8	10	489329
B45AF5550	A/F5.5	50	9	10	489304
B45AF5575	A/F5.5	75	9	10	424281
B45AF55100	A/F5.5	100	9	10	424380
B45AF55150	A/F5.5	150	9	10	424265 ☆
B45AF650	A/F6	50	10	10	489305
B45AF675	A/F6	75	10	10	424282 ☆
B45AF6100	A/F6	100	10	10	424381
B45AF6150	A/F6	150	10	10	424266 ☆
B45AF750	A/F7	50	13.5	10	489306
B45AF71175	A/F7	75	11	10	424279
B45AF775	A/F7	75	13.5	10	424283 ☆
B45AF711100	A/F7	100	11	10	424280
B45AF7100	A/F7	100	13.5	10	424382 ☆
B45AF7150	A/F7	150	13.5	10	424267 ☆
B45AF850	A/F8	50	13.5	10	489307
B45AF875	A/F8	75	13.5	10	424284 ☆
B45AF8100	A/F8	100	13.5	10	424383 ☆
B45AF8150	A/F8	150	13.5	10	424483 ☆
B45AF950	A/F9	50	16	10	489308
B45AF1050	A/F10	50	16	10	489309
B45AF1075	AF/10	75	16	10	424286 ☆
B45AF10100	AF/10	100	16	10	424384 ☆
B45AF10150	AF/10	150	16	10	424484 ☆
B45AF1150	A/F11	50	17	10	489310
B45AF1175	A/F11	75	17	10	424270 ☆
B45AF11100	A/F11	100	17	10	424271 ☆
B45AF1250	A/F12	50	18	10	489311
B45AF1275	A/F12	75	18	10	424287 ☆
B45AF12100	A/F12	100	18	10	424385 ☆
B45AF12150	A/F12	150	18	10	424272 ☆
B45AF1350	A/F13	50	19	10	489312
B45AF1375	AF/13	75	19	10	424288 ☆
B45AF13100	AF/13	100	19	10	424386 ☆
B45AF1450	A/F14	50	20	10	489313
B45AF1475	A/F14	75	20	10	424289 ☆
B45AF14100	A/F14	100	20	10	424387 ☆

☆ = Adopts a patented axial press-fit shank technique.

Nutsetter 1/4" Hex Magnet Nutsetter Metric

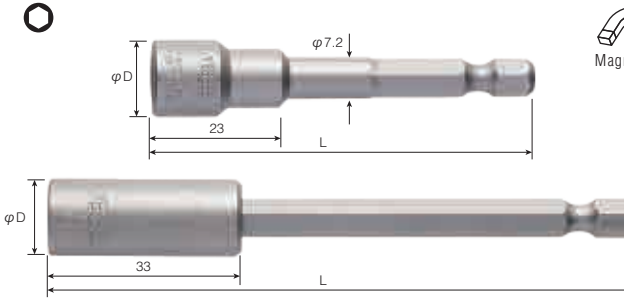

Model No.	Socket Size	Overall Length	Socket Nose Diameter φ	Inner Ctn.	Code
MB45AF550	A/F5	50	8.5	10	489340
MB45AF575	A/F5	75	8.5	10	489351
MB45AF5100	A/F5	100	8.5	10	489362
MB45AF5550	A/F5.5	50	9	10	489341
MB45AF5575	A/F5.5	75	9	10	489352
MB45AF650	A/F6	50	10	10	489342
MB45AF675	A/F6	75	10	10	489353
MB45AF6100	A/F6	100	10	10	489364
MB45AF750	A/F7	50	13	10	489343
MB45AF765	A/F7	65	13	10	482520
MB45AF775	A/F7	75	13	10	489354
MB45AF7100	A/F7	100	13	10	489365
MB45AF7150	A/F7	150	13.5	10	446622
MB45AF850	A/F8	50	13.5	10	489344
MB45AF865	A/F8	65	13.5	10	482521 ☆
MB45AF875	A/F8	75	13.5	10	482523
MB45AF8100	A/F8	100	13.5	10	482524 ☆
MB45AF8150	A/F8	150	13.5	10	424274 ☆
MB45AF950	A/F9	50	14	10	489345
MB45AF9665	A/F9.6	65	15	10	482522 ☆
MB45AF1050	A/F10	50	16	10	489346
MB45AF1075	A/F10	75	16	10	482525 ☆
MB45AF10100	A/F10	100	16	10	482526 ☆
MB45AF10150	A/F10	150	16	10	424275 ☆
MB45AF1150	A/F11	50	17	10	489347
MB45AF1175	A/F11	75	17	10	489358
MB45AF11100	A/F11	100	17	10	489369
MB45AF1250	A/F12	50	19	10	489348
MB45AF1275	A/F12	75	18	10	424276 ☆
MB45AF12100	A/F12	100	18	10	424277 ☆
MB45AF12150	A/F12	150	18	10	424278 ☆
MB45AF1350	A/F13	50	19	10	489349
MB45AF1375	A/F13	75	19	10	489360
MB45AF13100	A/F13	100	19	10	489371
MB45AF13150	A/F13	150	19	10	446626
MB45AF1475	A/F14	75	20	10	489361
MB45AF14100	A/F14	100	20	10	489372

☆ = Adopts a patented axial press-fit shank technique.

Nutsetter 1/4" Hex Sliding Magnet Nutsetter Metric

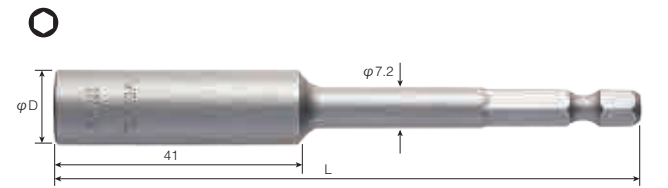

Model No.	Socket Size	Overall Length	Socket Nose Diameter φ	Inner Ctn.	Code
MB45DAF8100	A/F8	100	13	10	482516
MB45DAF10100	A/F10	100	16	10	482517

Nutsetter 1/4" Hex Side Magnet Nutsetter Metric



Model No.	Socket Size	Overall Length	Socket Nose Diameter φ	Inner Ctn.	Code
MB45SAF8100	A/F8	100	13	10	482406
MB45SAF10100	A/F10	100	16	10	482407

Features of press-fit type sockets

(Press-fit type: marked with a star symbol in the table of each model)

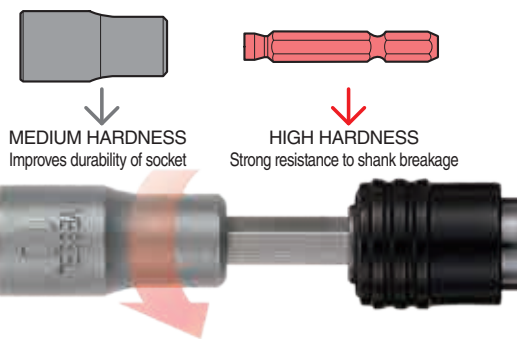

The shank and socket have been heat-treated to the best hardness and press-fit together. The socket part is strong against wear and shank against twisting, resulting in higher durability.

Prevents shank breakage
Torsion moment with a static torque

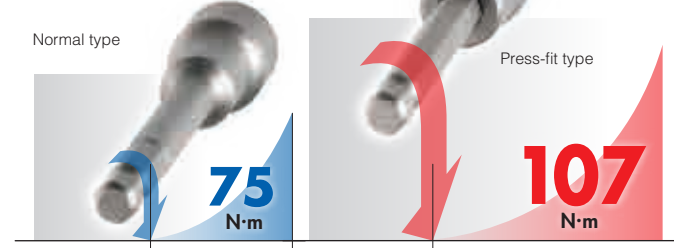

220USB SERIES

MEGADORA SCREWDRIVER

BALL GRIP SCREWDRIVER

SUPER CUSHION SCREWDRIVER

WOOD COMPO SERIES

FOR ELECTRONICS TOOLS/ USEFUL TOOLS

DRIVER SET SERIES

OTHER HAND TOOLS

L-WRENCH

IMPACT BALL

NECK-TORSION

DRYWALLER/ QB

INSERT BITS

POWER BITS

POWER BITS/ MAG CATCHER

DOUBLE-ENDED POWER BITS

NUT SETTERS

Bit Holder

PRECISION BITS

Bit Holder

220USB SERIES

MEGADORA SCREWDRIVER

BALL GRIP SCREWDRIVER

SUPER CUSHION SCREWDRIVER

WOOD COMPO SERIES

FOR ELECTRONICS TOOLS/ USEFUL TOOLS

DRIVER SET SERIES

OTHER HAND TOOLS

L-WRENCH

IMPACT BALL

NECK-TORSION

DRYWALLER/ QB

INSERT BITS

POWER BITS

POWER BITS/ MAG CATCHER

DOUBLE-ENDED POWER BITS

NUT SETTERS

Bit Holder

PRECISION BITS



TORSION ZONE ABSORB SHOCKS

Torsion part absorbs the impact caused by an impact driver when the screw head is fully seated. It helps preventing tip breakage as much as possible.

NECK TORSION

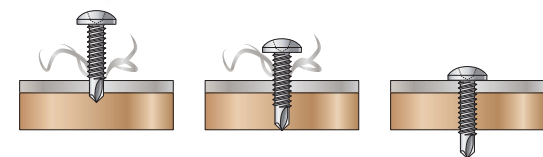

Drive : 1/4 DIN 3126-E6.3, ISO 1173  H 6.35 mm

Bit Holder 1/4" Hex Magnet Bit Holder



Model No.	Socket Size	Overall Length	Socket Nose Diameter φ	Inner Ctn.	Code
HBMAF63575	6.4(1/4")	75(3")	11.2(7/16")	10	482425

Bit Holder 1/4" Hex Bit Holder w.C-pin

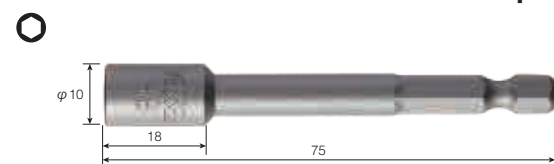

Model No.	Socket Size	Overall Length	Socket Nose Diameter φ	Inner Ctn.	Code
HBAF63575	6.4(1/4")	75(3")	10(13/32")	10	482420

IMPACT BALL™ Torsion Magnet Bit Holder

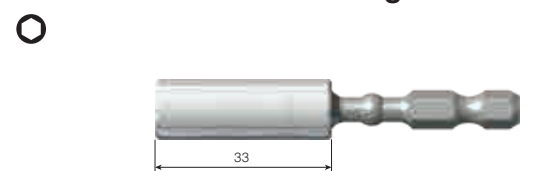

Model No.	Socket Size	Overall Length	Socket Nose Diameter φ	Inner Ctn.	Code
IBHBM67P10K	6.4	67	11.2	10	426099
IBHBM150P10K	6.4	150	11.2	10	426100
IBHBM300P10K	6.4	300	11.2	10	426101

Hex Socket Adapter



Model No.	Drive Size	Overall Length	Inner Ctn.	Code
B35SA63575	6.35	75	10	487382
B35SA635100	6.35	100	10	487383
B35SA635150	6.35	150	10	487384
B35SA9550	9.6	50	10	487391
B35SA9575	9.6	75	10	487392
B35SA95100	9.6	100	10	487393
B35SA95150	9.6	150	10	487394

Precision Bits

220USB SERIES

MEGADORA SCREWDRIVER

BALL GRIP SCREWDRIVER

SUPER CUSHION SCREWDRIVER

WOOD COMPO SERIES

FOR ELECTRONICS TOOLS/ USEFUL TOOLS

DRIVER SET SERIES

OTHER HAND TOOLS

L-WRENCH

IMPACT BALL

NECK-TORSION

DRYWALLER/ QB

INSERT BITS

POWER BITS

POWER BITS/ MAG CATCHER

DOUBLE-ENDED POWER BITS

NUT SETTERS

Bit Holder

PRECISION BITS

Drive : 4mm HIOS direct drive  φ 4 mm

Phillips Precision Bit

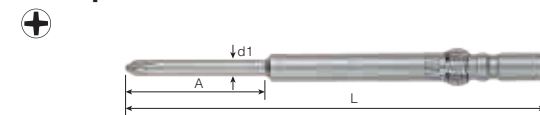

Model No.	Tip Size	Overall Length	Diameter (d1)	Length (A)	Inner Ctn.	Code
D73P00122040	PH00	40	1.2	20	10	446001
D73P00152040	PH00	40	1.5	20	10	483001
D73P00152060	PH00	60	1.5	20	10	483002
D73P00152080	PH00	80	1.5	20	10	483003
D73P00172040	PH00	40	1.7	20	10	446004
D73P0022040	PH00	40	2	20	10	483005
D73P0022060	PH00	60	2	20	10	483006
D73P0142040	PH0	40	1.4	20	10	446016
D73P0142060	PH0	60	1.4	20	10	446017
D73P0142080	PH0	80	1.4	20	10	483008
D73P0152040	PH0	40	1.5	20	10	446022
D73P0152060	PH0	60	1.5	20	10	446076
D73P0172040	PH0	40	1.7	20	10	483010
D73P0172060	PH0	60	1.7	20	10	483011
D73P0172080	PH0	80	1.7	20	10	483012
D73P0182060	PH0	60	1.8	20	10	483013
D73P022040	PH0	40	2	20	10	446025
D73P022060	PH0	60	2	20	10	446026
D73P023060	PH0	60	2	30	10	446029
D73P022080	PH0	80	2	20	10	446027
D73P0220100	PH0	100	2	20	10	446028
D73P0220120	PH0	120	2	20	10	483014
D73P0252040	PH0	40	2.5	20	10	483015
D73P0252060	PH0	60	2.5	20	10	483016
D73P0252080	PH0	80	2.5	20	10	446033
D73P02520100	PH0	100	2.5	20	10	446034
D73P02520120	PH0	120	2.5	20	10	483017
D73P1252040	PH1	40	3	20	10	446048
D73P132040	PH1	40	3	20	10	483021
D73P132060	PH1	60	3	20	10	446053
D73P132080	PH1	80	2	20	10	446054
D73P1320100	PH1	100	3	20	10	446055
D73P1320120	PH1	120	3	20	10	483376
D73P140	PH1	40	4	-	10	483025
D73P160	PH1	60	4	-	10	446059
D73P180	PH1	80	4	-	10	483026
D73P1100	PH1	100	4	-	10	483027
D73P1120	PH1	120	4	-	10	483028
D73P1150	PH1	150	4	-	10	483029
D73P1200	PH1	200	4	-	10	483032
D73P240	PH2	40	4	-	10	483031
D73P260	PH2	60	4	-	10	446070
D73P280	PH2	80	4	-	10	446071
D73P2100	PH2	100	4	-	10	446072
D73P2120	PH2	120	4	-	10	446073
D73P2150	PH2	150	4	-	10	483033

Slotted Precision Bit

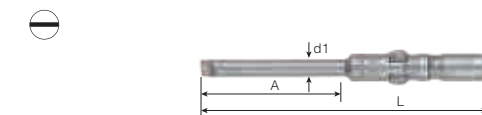

Model No.	Overall Length	Tip Width/ Shank Diameter	Length (A)	Inner Ctn.	Code
D73S20340	40	2	20	10	483041
D73S250340	40	2.5	20	10	483042
D73S30440	40	3	20	10	483043
D73S40540	40	4	-	10	483044

Hex Precision Bit

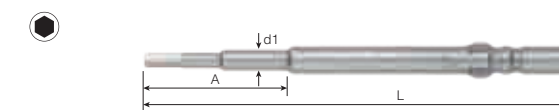

Model No.	Tip Size	Overall Length	Diameter (d1)	Length (A)	Inner Ctn.	Code
D73H1522060	H1.5	60	2	20	10	483051
D73H232060	H2	60	3	20	10	483052
D73H2532060	H2.5	60	3	20	10	483053
D73H3360	H3	60	4	-	100	483054

Torx Precision Bit

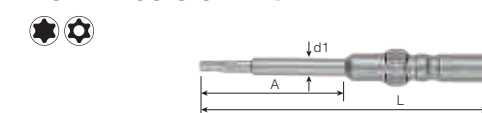

Model No.	Tip Size	Overall Length	Diameter (d1)	Length (A)	Inner Ctn.	Code
D73T1152040	T1	40	1.5	20	10	635621
D73T2152040	T2	40	1.5	20	10	635622
D73T3172040	T3	40	1.7	20	10	635623
D73T4182040	T4	40	1.8	20	10	635624
D73T522040	T5	40	2	20	10	635625
D73T522060	T5	60	2	20	10	446108
D73T6252040	T6	40	2.5	20	10	635626
D73T622040	T6	40	2	20	10	446109
D73T622060	T6	60	2	20	10	446110
D73T7252040	T7	40	2.5	20	10	635627
D73T722060	T7	60	2	20	10	446113
D73T832040	T8	40	3	20	10	635628
D73T932040	T9	40	3	20	10	635629
D73T1032040	T10	40	3	20	10	635630
D73T10H60	T10H	60	4	-	10	446119

Precision Bits

Drive : 5mm HIOS direct drive

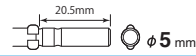

Phillips Precision Bit

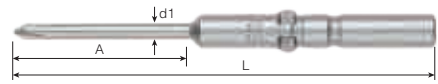

Model No.	Tip Size	Overall Length	Diameter (d1)	Length (A)	Inner Ctn.	Code
D76P0022060	PH00	60	2	20	10	483105
D76P022560	PH0	60	2	25	10	483106
D76P0252560	PH0	60	2.5	25	10	483115
D76P02525100	PH0	100	2.5	25	10	483117
D76P133060	PH1	60	3	30	10	483121
D76P133080	PH1	80	3	30	10	446267
D76P1330100	PH1	100	3	30	10	483122
D76P1330120	PH1	120	3	30	10	483123
D76P160	PH1	60	5	-	10	483125
D76P1100	PH1	100	5	-	10	483127
D76P1200	PH1	200	5	-	10	483132
D76P260	PH2	60	5	-	10	483131
D76P280	PH2	80	5	-	10	446279
D76P2100	PH2	100	5	-	10	446280
D76P2120	PH2	120	5	-	10	446281
D76P2150	PH2	150	5	-	10	446282
D76P2200	PH1	200	5	-	10	483137

Slotted Precision Bit

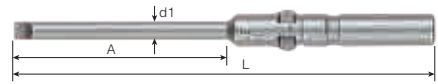

Model No.	Overall Length	Tip Width/ Shank Diameter	Length (A)	Inner Ctn.	Code
D76S30434060	60	3	40	10	483141
D76S40643060	60	4	30	10	483142
D76S50760	60	5	-	10	483143

Hex Precision Bit

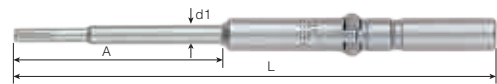

Model No.	Tip Size	Overall Length	Diameter (d1)	Length (A)	Inner Ctn.	Code
D76H233070	H2	70	3	30	10	483151
D76H2533070	H2.5	70	3	30	10	483152
D76H343070	H3	70	4	30	10	483153
D76H470	H4	70	5	-	10	483154

Torx Precision Bit



Model No.	Tip Size	Overall Length	Diameter (d1)	Length (A)	Inner Ctn.	Code
D76T522060	T5	60	2	20	10	635651
D76T6252060	T6	60	2.5	20	10	635652
D76T7252060	T7	60	2.5	20	10	635653
D76T832060	T8	60	3	20	10	635654
D76T932060	T9	60	3	20	10	635655
D76T1032060	T10	60	3	20	10	635656
D76T1542060	T15	60	4	20	10	635657
D76T2060	T20	60	5	-	10	635658
D76T2560	T25	60	5	-	10	635659

Drive : 4mm HIOS direct drive

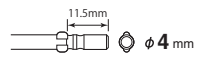

Nutsetter



Model No.	Socket Size	Overall Length	Socket Nose Diameter φ	Inner Ctn.	Code
D73AF460	A/F4	60	8	10	483924
D73AF560	A/F5	60	8	10	483926
D73AF5560	A/F5.5	60	8	10	483927

Drive : 4mm half moon direct drive

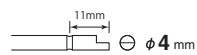

Phillips Precision Bit

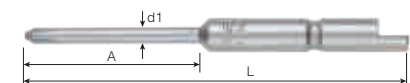

Model No.	Tip Size	Overall Length	Diameter (d1)	Length (A)	Inner Ctn.	Code
D71P001544	PH00	44	1.5	20	10	482901
D71P001564	PH00	64	1.5	20	10	482902
D71P0244	PH0	44	2	20	10	482911
D71P0264	PH0	64	2	20	10	482912
D71P02544	PH0	44	2.5	20	10	482913
D71P02564	PH0	64	2.5	20	10	482914
D71P1344	PH1	44	3	20	10	482921
D71P1364	PH1	64	3	20	10	482922
D71P1444	PH1	44	4	20	10	482923
D71P1464	PH1	64	4	20	10	482924
D71P2444	PH2	44	4	20	10	482931
D71P2464	PH2	64	4	20	10	482932

Slotted Precision Bit

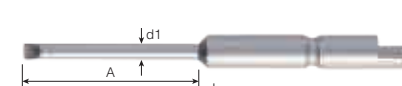

Model No.	Overall Length	Tip Width/ Shank Diameter	Length (A)	Inner Ctn.	Code
D71S20344	44	2	20	10	482941
D71S250344	44	2.5	20	10	482942
D71S30444	44	3	20	10	482943
D71S40544	44	4	20	10	482944

Hex Precision Bit

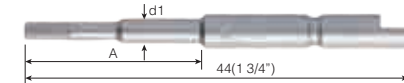

Model No.	Tip Size	Overall Length	Diameter (d1)	Length (A)	Inner Ctn.	Code
D71H15244	H1.5	44	2	20	10	482951
D71H2344	H2	44	3	20	10	482952
D71H25344	H2.5	44	3	20	10	482953
D71H3444	H3	44	4	-	10	482954

Torx Precision Bit

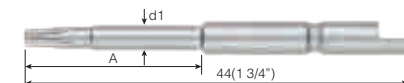

Model No.	Tip Size	Overall Length	Diameter (d1)	Length (A)	Inner Ctn.	Code
D71T144	T1	44	1.5	20	10	635601
D71T244	T2	44	1.5	20	10	635602
D71T344	T3	44	1.7	20	10	635603
D71T444	T4	44	1.8	20	10	635604
D71T544	T5	44	2.5	20	10	635605
D71T644	T6	44	2.5	20	10	635606
D71T744	T7	44	2.5	20	10	635607
D71T844	T8	44	3	20	10	635608
D71T944	T9	44	3	20	10	635609
D71T1044	T10	44	3	20	10	635610
D71T8H44	T8H	44	4	-	10	446323
D71T15H44	T15H	44	4	-	10	446328

Torx Plus Precision Bit

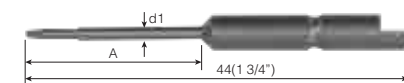

Model No.	Tip Size	Overall Length	Diameter (d1)	Length (A)	Inner Ctn.	Code
D71IP244	2IP	44	4	00	10	447428
D71IP264	2IP	64	4	00	10	447412
D71IP344	3IP	44	4	00	10	447429
D71IP364	3IP	64	4	00	10	447413

Nutsetter Precision Bit

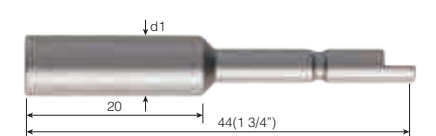

Model No.	Tip Size	Overall Length	Diameter (d1)	Inner Ctn.	Code
D72AF444	A/F4	44	7	10	482961
D72AF4544	A/F4.5	44	7	10	482962
D72AF544	A/F5	44	8	10	482963
D72AF5544	A/F5.5	44	8	10	482964

Drive : M5/M6



Screw Shank Driver Bit

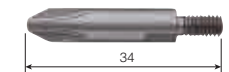

Model No.	Tip Size	Overall Length	Screw Pitch	Inner Ctn.	Code
M4P07P134	PH1	34	P0.7	10	489656
M4P07P234	PH2	34	P0.7	10	489657